

LOCATION MAP
N.T.S.

WILLIAMS ARROYO GABION WALL REPAIR CIVIL SITE CONSTRUCTION PLANS AZTEC, NEW MEXICO

BY:
CITY OF AZTEC
201 W. CHACO

AZTEC, NEW MEXICO 87410



APRIL 5, 2024



SHEET INDEX	
SHEET NO.	SHEET TITLE
1	COVER SHEET
2	GENERAL NOTES
3	STAGING AND EROSION CONTROL PLAN
4	PLAN AND PROFILE
5	PLAN AND PROFILE
6	CROSS SECTIONS
7	DETAIL SHEET

SURVEY:

RED MOUNTAIN LAND SURVEYING
(970) 903-2024

TBM 1
DESC: 1/2" REBAR AND YELLOW PLASTIC CAP
NORTHING: 2117728.4770
EASTING: 2672402.4450
ELEV: 5590.68

TBM 2
DESC: 60D NAIL IN ISLAND
NORTHING: 2117612.9660
EASTING: 2672336.5890
ELEV: 5589.14

APPLICABLE PERMITS

PERMIT 1: USACE NATIONWIDE PERMIT VERIFICATION
SPA-2023.00371
NATIONWIDE PERMIT 13-BANK STABILIZATION
CONTRACTOR RESPONSIBLE FOR BEST MANAGEMENT PRACTICES
ASSOCIATED WITH NWP13.

UTILITY OWNERS:

CITY OF AZTEC DEPARTMENT OF PUBLIC WORKS
(505) 334-7660

CITY OF AZTEC ELECTRIC DEVELOPMENT
(505) 334-7660

QWEST (TELEPHONE)
(505) 325-2311

COMCAST CABLE
VICTOR APPEGATE (505) 402-0055

PNM (GAS)
(505) 324-3783

ALL COORDINATES ARE IN NSRS11.NM-WF UNLESS OTHERWISE NOTED.

A PORTION OF THIS PROJECT LIES WITHIN THE FEMA 100-YEAR FLOODPLAIN (ZONE A), FIRM PANEL 35045C0710F, EFFECTIVE DATE AUGUST 5, 2010.

ENGINEER AND OWNER DISCLAIM ALL RESPONSIBILITY FOR IDENTIFYING SUBSURFACE UTILITIES. CONTRACTOR SHALL BE HELD SOLELY RESPONSIBLE FOR IDENTIFYING, LOCATING, AND PROTECTING UTILITIES PRIOR TO EXCAVATION.

CONTRACTOR SHALL FIELD ALL DIMENSIONS AND QUANTITIES IN THE FIELD PRIOR TO BEGINNING WORK.

CONTRACTOR IS SOLELY RESPONSIBLE FOR SCHEDULING ALL REQUIRED INSPECTIONS.

CONTRACTOR SHALL MAINTAIN A CURRENT SET OF CONSTRUCTION PLANS AT THE CONSTRUCTION SITE AT ALL TIMES.

RELEASE OF THIS APPLICATION DOES NOT CONSTITUTE A VERIFICATION OF ALL DATA, INFORMATION, AND CALCULATIONS SUPPLIED BY THE APPLICANT. THE ENGINEER OF RECORD IS SOLELY RESPONSIBLE FOR THE COMPLETENESS, ACCURACY, AND ADEQUACY OF HIS/HER SUBMITTAL, WHETHER OR NOT THE APPLICATION IS REVIEWED FOR CODE COMPLIANCE BY CITY ENGINEERS.

ALL RESPONSIBILITY FOR THE ADEQUACY OF THESE PLANS REMAINS WITH THE ENGINEER WHO PREPARED THEM. IN APPROVING THESE PLANS, THE CITY OF AZTEC MUST RELY UPON THE ADEQUACY OF THE WORK OF THE DESIGN ENGINEER.

REVISIONS		
NO.	REVISION DESCRIPTION	DATE
1	Update quantities sheet 2, detail sheet 7	1/7/2025

Know what's below.
Call before you dig.

It's the Law!

New Mexico One Call, Inc.
NMOC
Professional Resources for Damage Prevention

AquaStrategies

Water Planning, Science & Engineering

Aqua Strategies Inc.
13341 W. US Hwy 290, Bldg. 2
Dripping Springs, TX 78620-5000
www.aquastrategies.com
(512) 826-2604

GENERAL NOTES:

1. THE "NEW MEXICO DEPARTMENT OF TRANSPORTATION STANDARD SPECIFICATIONS FOR HIGHWAY AND BRIDGE CONSTRUCTION, 2019 EDITION", SHALL GOVERN CONSTRUCTION OF THIS PROJECT UNLESS OTHERWISE NOTED ON THESE PLANS OR IN THE CONTRACT DOCUMENTS. IN CASE OF CONFLICT BETWEEN PLANS AND SPECIFICATIONS, THE PLANS SHALL GOVERN.
2. NO PAYMENT WILL BE MADE FOR ANY HAULING OF MATERIALS. THE TRANSPORTATION OF MATERIALS SHALL BE CONSIDERED INCIDENTAL TO THE ITEM TO WHICH THE WORK PERTAINS.
3. THE CONTRACTOR SHALL NOTIFY THE CITY OF AZTEC AND THE CITY OF AZTEC FIRE DEPARTMENT 24 HOURS BEFORE CONSTRUCTION ACTIVITIES BEGIN.
4. THE CONTRACTOR IS RESPONSIBLE FOR MAINTAINING THE STREET FREE AND CLEAR OF ANY DEBRIS THAT IS TRACKED FROM THE SITE.
5. ALL ACCESS ROADS SHALL BE SERVICEABLE AND MAINTAINED FOR FIRE PROTECTION AND EMERGENCY VEHICLES PRIOR TO AND DURING CONSTRUCTION.
6. THE CONTRACTOR SHALL PROVIDE REASONABLE ACCESS TO PROPERTY OWNERS AFFECTED BY THE CONSTRUCTION. ALL AFFECTED RESIDENTS SHALL BE INFORMED OF ANY LANE OR ROAD CLOSURES AT LEAST 48 HOURS PRIOR TO CLOSURE. ACCESS TO RESIDENCIES SHALL NOT BE DENIED FOR MORE THAN 24 HOURS WITHOUT THE APPROVAL OF THE PROJECT MANAGER.
7. OVERNIGHT PARKING OF THE CONTRACTOR'S EQUIPMENT SHALL NOT OBSTRUCT DRIVEWAY OPENINGS OR DESIGNATED TRAFFIC LANES.
8. CONTRACTOR SHALL KEEP WORK SITE IN AN ORDERLY CONDITION. DURING CONSTRUCTION. AT COMPLETION OF WORK, CONTRACTOR SHALL REMOVE ALL DEBRIS AND LEAVE WORK SITE IN A CONDITION ACCEPTABLE TO THE CITY ENGINEER.
9. THE CONTRACTOR IS RESPONSIBLE FOR REPORTING ANY DISCREPANCIES DISCOVERED IN THE PLANS AND SPECIFICATIONS PROMPTLY TO THE CITY ENGINEER IN WRITING.
10. THE CONTRACTOR IS RESPONSIBLE FOR LOCATING AND PROTECTING ALL UNDERGROUND, SURFACE AND AERIAL UTILITIES, CONSTRUCTIONS AND STRUCTURES WHETHER ON PUBLIC OR PRIVATE PROPERTY DAMAGES THERETO BY THE CONTRACTOR SHALL BE REPLACED IN KIND OR BETTER AT NO EXPENSE TO THE PROJECT.
11. THE CONTRACTOR SHALL BE RESPONSIBLE FOR ALL REMOVALS REQUIRED TO COMPLETE THIS PROJECT.

PAVING NOTES:

1. ANY EXISTING PAVEMENT, CURBS, AND/OR SIDEWALKS DAMAGED OR REMOVED WILL BE REPAIRED BY THE CONTRACTOR AT CONTRACTOR'S EXPENSE BEFORE ACCEPTANCE OF THE PROJECT.
2. MANHOLE FRAMES, COVERS, WATER VALVE COVERS, AND OTHER EXISTING UTILITIES SHALL BE RAISED TO FINISHED GRADE AT THE CONTRACTOR'S EXPENSE BY A QUALIFIED CONTRACTOR WITH ENGINEER INSPECTION. ALL UTILITY ADJUSTMENTS SHALL BE COMPLETED PRIOR TO FINAL PAVING CONSTRUCTION.
2. CONTRACTOR SHALL BE RESPONSIBLE FOR PREPARING ROAD BASE MATERIAL CONSISTING OF EXISTING AND IMPORTED MATERIAL.
3. CONTRACTOR SHALL SAW CUT TACK AND MATCH EXISTING PAVEMENT.
4. THE CONTRACTOR WILL NOTIFY THE AZTEC PUBLIC WORKS DIRECTOR AT LEAST 4 HOURS PRIOR TO PAVING.
5. FLAGGING SHALL BE PROVIDED FOR SAFETY WHERE NEEDED AND REQUIRED BY THE MUTCD OR AS DIRECTED BY THE CITY ENGINEER. ALL FLAGGING OPERATIONS SHALL COMPLY WITH THE REQUIREMENTS OF THE MUTCD. FLAGGERS SHALL BE CONSIDERED INCIDENTAL TO PAYMENT FOR TRAFFIC CONTROL AND NO MEASUREMENT OR PAYMENT WILL BE MADE FOR THIS SERVICE.
6. TRAFFIC CONTROL DEVICES SHALL REMAIN IN OPERATION AT ALL TIMES DURING CONSTRUCTION.

UTILITIES:

1. THE EXISTENCE AND LOCATION OF UNDERGROUND UTILITY PIPES, CONDUITS AND STRUCTURES ARE SHOWN WHERE KNOWN TO EXIST. CONTRACTOR SHALL CONFIRM THE LOCATION OF ALL UTILITIES PRIOR TO START OF CONSTRUCTION AND SHALL TAKE PRECAUTIONARY MEASURES TO PROTECT ALL UTILITIES.
2. UTILITY CONFLICTS ARE NOT ANTICIPATED ON THIS PROJECT SINCE EXCAVATION WILL BE LIMITED. IF UTILITIES ARE ENCOUNTERED THE CONTRACTOR SHALL COORDINATE AND COOPERATE WITH ALL UTILITY COMPANIES AND THE CITY OF AZTEC WITH REGARDS TO RELOCATING, ADJUSTING, REPLACING, AND REPAIRING UTILITIES DURING CONSTRUCTION.
3. THE CONTRACTOR SHALL BE RESPONSIBLE FOR REPORTING AND CLEAN UP OF SPILLS ASSOCIATED WITH PROJECT CONSTRUCTION AND SHALL REPORT AND RESPOND TO SPILLS OF HAZARDOUS MATERIAL SUCH AS GASOLINE, DIESEL, MOTOR OILS, SOLVENTS, SEWER CHEMICALS, TOXIC AND CORROSIVE SUBSTANCES, AND OTHER MATERIALS WHICH MAY BE A THREAT TO PUBLIC HEALTH OR THE ENVIRONMENT. THE CONTRACTOR SHALL BE RESPONSIBLE FOR REPORTING PAST SPILLS ENCOUNTERED DURING CONSTRUCTION AND OF CURRENT SPILLS NOT ASSOCIATED WITH CONSTRUCTION. REPORTS SHALL BE MADE IMMEDIATELY TO THE NM ENVIRONMENT DEPARTMENT AT (505) 827-9329.

CONSTRUCTION TESTING:

1. THE PROJECT WILL HAVE VERIFICATION, AND DENSITY TESTS COMPLETED BY A GEOTECHNICAL ENGINEERING COMPANY TO VERIFY COMPACTION.
2. THE CITY WILL USE GEOMAT TO PROVIDE QUALITY ASSURANCE TESTING. THE CONTRACTOR SHALL COORDINATE WITH GEOMAT FOR REQUIRED TESTING. CONTRACTOR SHALL PROVIDE QUALITY CONTROL TESTING AS NECESSARY TO PROVIDE ACCEPTABLE WORK QUALITY THAT CONFORMS TO THE GOVERNING SPECIFICATIONS NECESSARY. RETESTING BY GEOMAT WILL BE CHARGED BACK TO THE CONTRACTOR. GEOMAT CONTACT PHONE - 505-327-7928.
3. ROAD BASE MATERIAL SHALL BE COMPACTED TO 95% OF MAXIMUM DENSITY PER NMDOT SPECIFICATIONS SECTION 203.3.5 "MOISTURE AND DENSITY CONTROL."
4. SP-IV ASPHALT SHALL BE COMPACTED TO A MEAN DENSITY OF 93% OF THE THEORETICAL MAXIMUM DENSITY. REFER TO NMDOT SPECIFICATION DIVISION 473.
5. ASPHALT MIX DESIGN SHALL BE PER NMDOT SP-IV DESIGN ASPHALT MIX SHALL BE TESTED BY GEOMAT.
6. GRADATION OF PROPOSED IMPORTED ROADBASE OR BULK MATERIAL SHALL BE SUBMITTED TO GEOMAT FOR APPROVAL PRIOR TO IMPORT AND TO THE AZTEC PUBLIC WORKS DIRECTOR.
7. NO MATERIAL PITS HAVE BEEN DESIGNATED FOR THIS PROJECT. THE CONTRACTOR MAY OBTAIN SPECIFICATION BORROW AND SURFACING MATERIAL FROM ANY ACCEPTABLE SOURCE ALL MATERIAL SHALL BE GOVERNED BY APPROPRIATE SECTIONS OF THE NMDOT STANDARD.

WATER CONTROL PLAN

1. CONTRACTOR TO BE RESPONSIBLE FOR MANAGEMENT OF WATER.

PHASE 1 – MATERIALS ESTIMATE

ITEM	DESCRIPTION	QUANTITY	UNIT	CONTRACTOR BID	
				UNIT COST	COST
BASE PROJECT ITEMS					
1	Mobilization and Demobilization	1.0	UNIT		
2	Temporary Security Fencing 6'	100.0	L.F.		
3	Erosion Control - Rock Berm	60.0	L.F.		
4	Erosion Control - Inlet Protection	1.0	UNIT		
5	Gabion Mat 1.5'x10'x1' HxWxLength	70.0	L.F.		
6	Gabion 3'X3'x1ft HxWxL	70.0	L.F.		
7	Gabion 3'X4'x1ft HxWxL	70.0	L.F.		
8	Gabion 3'X5'x1ft HxWxL	70.0	L.F.		
9B	Gabion Fill Option 2: 6" Riprap, Well Graded	133.0	C.Y.		
10	Gravel Base	16.0	C.Y.		
11	Gravel Drainage Stone	16.0	C.Y.		
12	Geotextile	218.0	S.Y.		
13	Remove Sidewalk	280.0	S.F.		
14	Replace Sidewalk	32.0	S.Y.		
21	Post and Cable Fencing	235.0	L.F.		
				TOTAL BASE ITEMS	
ALTERNATE PROJECT ITEMS					
9A	Gabion Fill Option 1: 24" Rock w/ Chokestone	133.0	C.Y.		
15	Remove Curb	70.0	L.F.		
16	Replace Curb	70.0	L.F.		
17	Remove Asphalt	1,400.0	S.F.		
18	Replace Asphalt	156.0	S.Y.		
19	Excavation	389.0	C.Y.		
20	Subgrade Preparation	78.0	S.Y.		
22	Culvert Headwall	0.0	UNIT		
				TOTAL ALTERNATE ITEMS	
				TOTAL BASE + ALTERNATE ITEMS	

EXCLUDED AREA NOT PART OF BID FOR PHASE 1

PHASE 2+PHASE 3

ITEM	DESCRIPTION	QUANTITY	UNIT	CONTRACTOR BID	
				UNIT COST	COST
BASE PROJECT ITEMS					
1	Mobilization and Demobilization	1.0	UNIT		
2	Temporary Security Fencing 6'	100.0	L.F.		
3	Erosion Control - Rock Berm	60.0	L.F.		
4	Erosion Control - Inlet Protection	1.0	UNIT		
5	Gabion Mat 1.5'x10'x1' HxWxLength	525.0	L.F.		
6	Gabion 3'X3'x1ft HxWxL	525.0	L.F.		
7	Gabion 3'X4'x1ft HxWxL	525.0	L.F.		
8	Gabion 3'X5'x1ft HxWxL	525.0	L.F.		
9B	Gabion Fill Option 2: 6" Riprap, Well Graded	1076.0	C.Y.		
10	Gravel Base	116.0	C.Y.		
11	Gravel Drainage Stone	116.0	C.Y.		
12	Geotextile	1,680.0	S.Y.		
13	Remove Sidewalk	840.0	S.F.		
14	Replace Sidewalk	94.0	S.Y.		
21	Post and Cable Fencing	335.0	L.F.		
				TOTAL BASE ITEMS	
ALTERNATE PROJECT ITEMS					
9A	Gabion Fill Option 1: 24" Rock w/ Chokestone	1076.0	C.Y.		
15	Remove Curb	210.0	L.F.		
16	Replace Curb	210.0	L.F.		
17	Remove Asphalt	4,200.0	S.F.		
18	Replace Asphalt	467.0	S.Y.		
19	Excavation	2,889.0	C.Y.		
20	Subgrade Preparation	578.0	S.Y.		
22	Culvert Headwall	0.0	UNIT		
				TOTAL ALTERNATE ITEMS	
				TOTAL BASE + ALTERNATE ITEMS	

* - only include Item 9A or 9B in total

AquaStrategies
Water Planning, Science & Engineering
Aqua Strategies Inc.
13341 W. US Hwy 290, Bldg. 2
Dripping Springs, TX 78620-5000
www.aquastrategies.com
(512) 826-2604

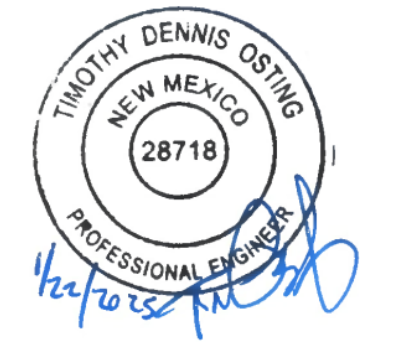

GENERAL NOTES
BANK STABILIZATION
WILLIAMS ARROYO HARTMAN PARK

NO.	REVISION DESCRIPTION	DATE
1	Update Materials Estimate Tables - All Phases	1/7/2025

DATE: **APRIL 5, 2024**
DESIGNED BY: **GC TDO**
DRAWN BY: **RT-MEI**
REVIEWED BY: **TDO**

SHEET
#
2



LEGEND

- 452 — EXISTING CONTOUR
- - - - - PROPOSED CONTOUR
- x — SILT FENCE
- x — LIMITS OF CONSTRUCTION
- x — FILTER DIKE/INLET PROTECTION
- x — FLOW ARROW
- x - x - TEMPORARY SECURITY FENCE

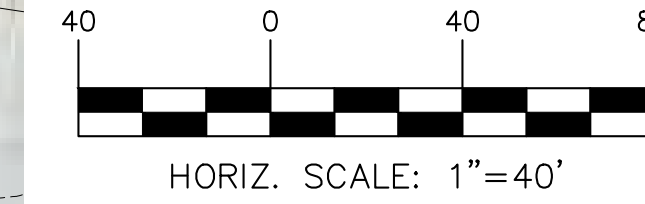

CONSTRUCTION SEQUENCING:

PHASE 1 SHALL BE CONSTRUCTED TO COMPLETION FIRST AS PART OF CURRENT BID PROJECT.
 PHASE 2 AND PHASE 3 SHALL BE CONSTRUCTED AS PART OF A SEPARATE BID PACKAGE AT A LATER DATE TO BE DETERMINED BY THE CITY.
 NOTE: OTHER CONTRACTORS COULD BE WORKING ON THIS SITE. COORDINATE ALL ACTIVITIES WITH THE ACTIVITIES OF OTHERS.

PHASE 1 SEQUENCE

1. NOTIFY ALL AFFECTED PARTIES AS PRESCRIBED UNDER GENERAL NOTES.
2. PRIOR TO STARTING CONSTRUCTION, CONSTRUCTION SHALL BE COMPLETED ACCORDING TO A TIMETABLE OF CONSTRUCTION AGREED UPON WITH THE ENGINEER. CONSTRUCTION IS TO BE SUBSTANTIALLY COMPLETE BY JUNE 26, 2024.
3. THE SEQUENCE OF CONSTRUCTION INSIDE PHASE 1 SHALL BE AS FOLLOWS:
 - a. INSTALL TEMPORARY EROSION CONTROLS PRIOR TO ANY GROUND DISTURBANCE.
 - b. THE ORDER OF CONSTRUCTION SHALL BE THE CONTRACTOR'S DECISION.
 - c. RESTORE SITE VEGETATION.
4. COMPLETE ANY NECESSARY FINAL DRESS-UP.

PHASE 2 AND PHASE 3

1. NOTIFY ALL AFFECTED PARTIES AS PRESCRIBED UNDER GENERAL NOTES.
2. PRIOR TO STARTING CONSTRUCTION, CONSTRUCTION SHALL BE COMPLETED ACCORDING TO A TIMETABLE OF CONSTRUCTION AGREED UPON WITH THE ENGINEER.
3. THE SEQUENCE OF CONSTRUCTION INSIDE PHASE 2 SHALL BE AS FOLLOWS:
 - a. INSTALL TEMPORARY EROSION CONTROLS PRIOR TO ANY GROUND DISTURBANCE.
 - b. THE ORDER OF CONSTRUCTION SHALL BE THE CONTRACTOR'S DECISION.
 - c. RESTORE SITE VEGETATION.
4. COMPLETE ANY NECESSARY FINAL DRESS-UP.

AquaStrategies
 Water Planning, Science & Engineering
 Aqua Strategies Inc.
 13341 W. US Hwy 290, Bldg. 2
 Dripping Springs, TX 78620-5000
 www.aquastrategies.com
 (512) 826-2604



**STAGING AND EROSION CONTROL PLAN
 BANK STABILIZATION
 WILLIAMS ARROYO HARTMAN PARK**

NO.	REVISION DESCRIPTION	DATE

DATE: **APRIL 5, 2024**
 DESIGNED BY: **GC TDO**
 DRAWN BY: **RT-MEI**
 REVIEWED BY: **TDO**

SHEET # 3

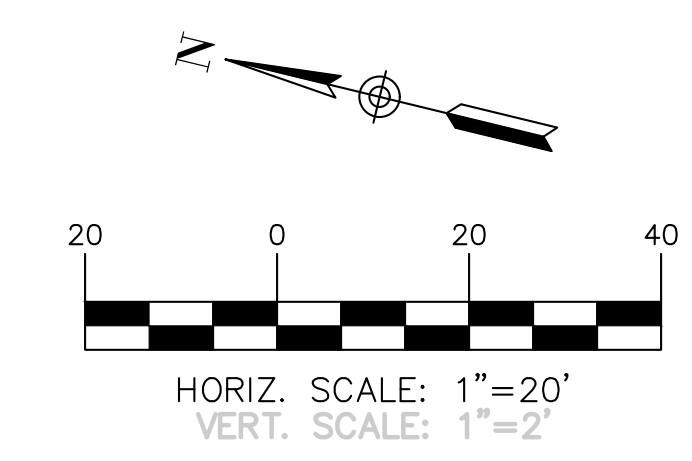
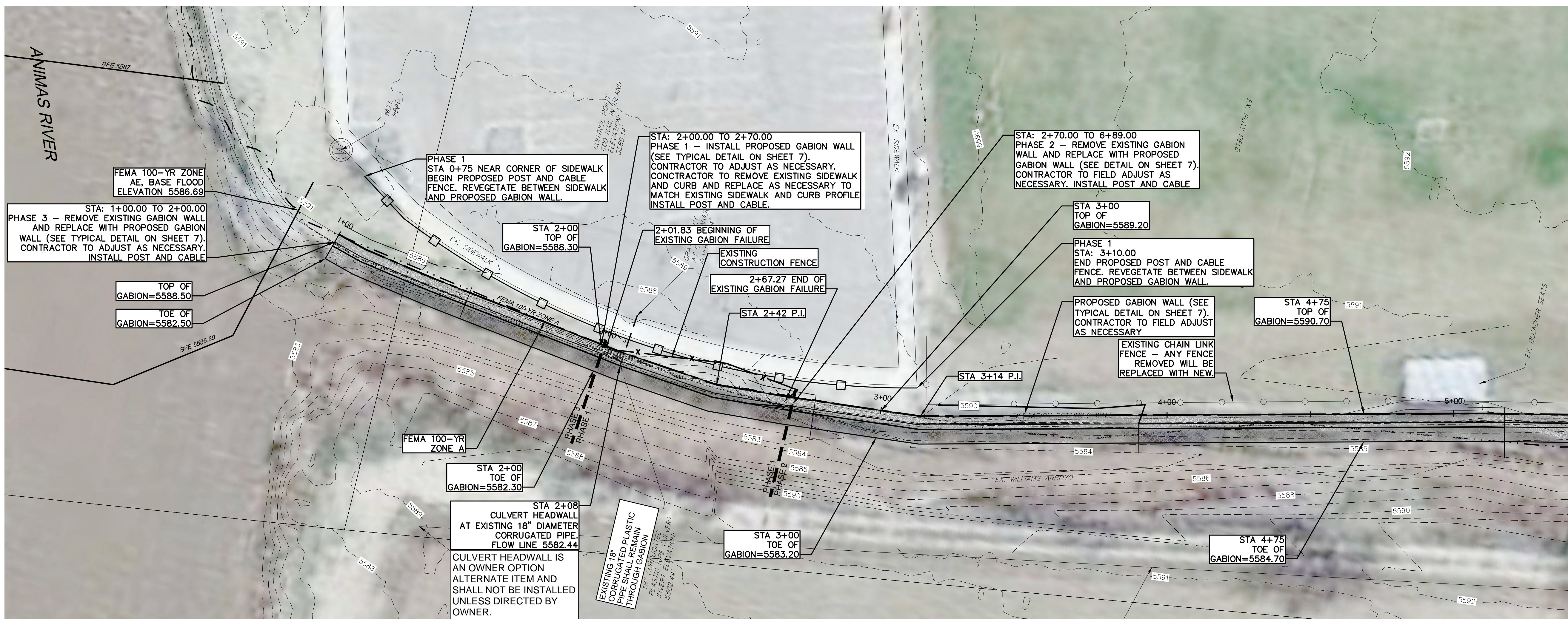

LEGEND

- 452 - EXISTING CONTOUR
- 552 - PROPOSED CONTOUR
- FLOW ARROW

- NOTES:**
- CONTRACTOR SHALL SECURE NEW GABIONS TO EXISTING UNDISTURBED ADJACENT GABIONS USING TYPICAL TIES.
 - CONTRACTOR SHALL TRANSITION FINISH GRADING SMOOTHLY BETWEEN NEW FILL AND EXISTING GRADE.
 - CONTRACTOR SHALL AVOID DISTURBING EXISTING CURB AND PAVEMENT WITHOUT PRIOR APPROVAL BY ENGINEER.

STA OF BACK OF GABION WALL	NORTHING	EASTING
1+00	2117688.83	2672302.28
2+00	2117590.17	2672286.51
2+42	2117548.40	2672282.37
3+00	2117490.58	2672287.19
3+14	2117476.65	2672288.48
4+75	2117320.38	2672327.25
6+83	2117117.79	2672374.34

AquaStrategies
 Water Planning, Science & Engineering

Aqua Strategies Inc.
 13341 W. US Hwy 290, Bldg. 2
 Dripping Springs, TX 78620-5000
 www.aquastrategies.com
 (512) 826-2604



EXCLUDED AREA NOT PART OF BID FOR PHASE 1

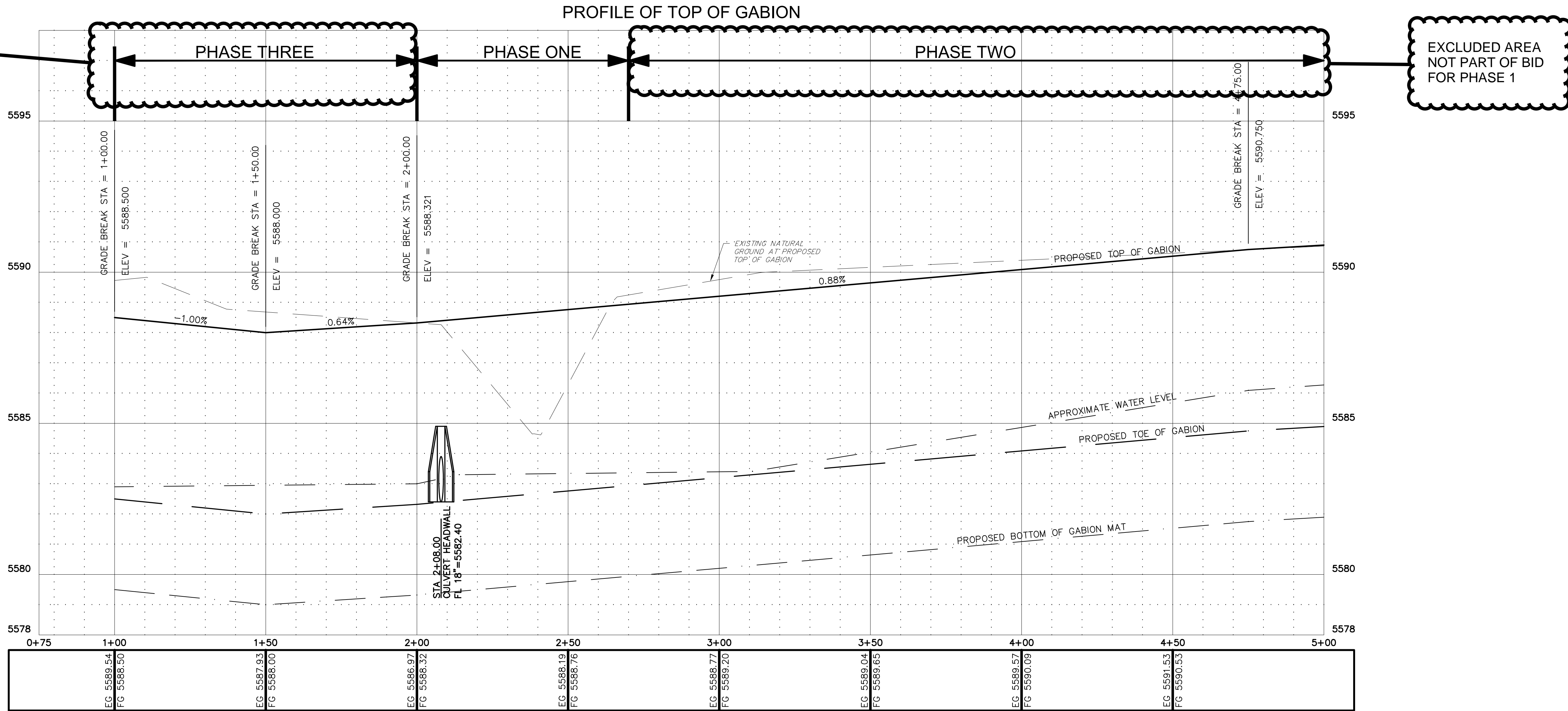

EXCLUDED AREA NOT PART OF BID FOR PHASE 1

PLAN AND PROFILE
BANK STABILIZATION
WILLIAMS ARROYO HARTMAN PARK

NO.	REVISIONS	DATE
1	REV. CULVERT HEADWALL AND REV. NOTES	01/23/25

DATE: APRIL 5, 2024
 DESIGNED BY: GC TDO
 DRAWN BY: RT-MEI
 REVIEWED BY: TDO

SHEET
 #
 4

EXCLUDED AREA
NOT PART OF BID
FOR PHASE 1

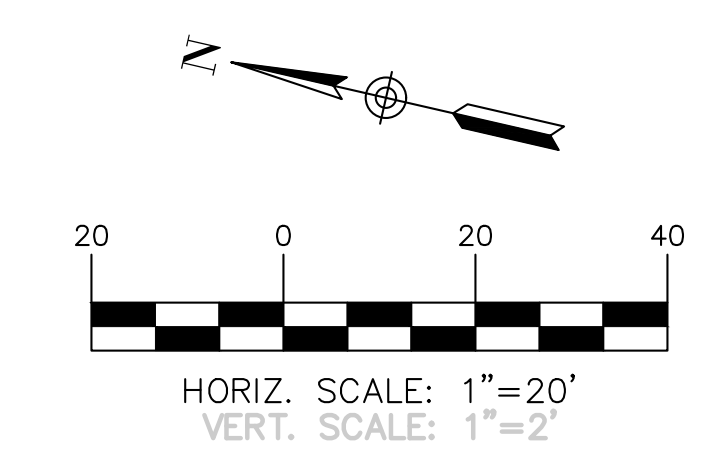
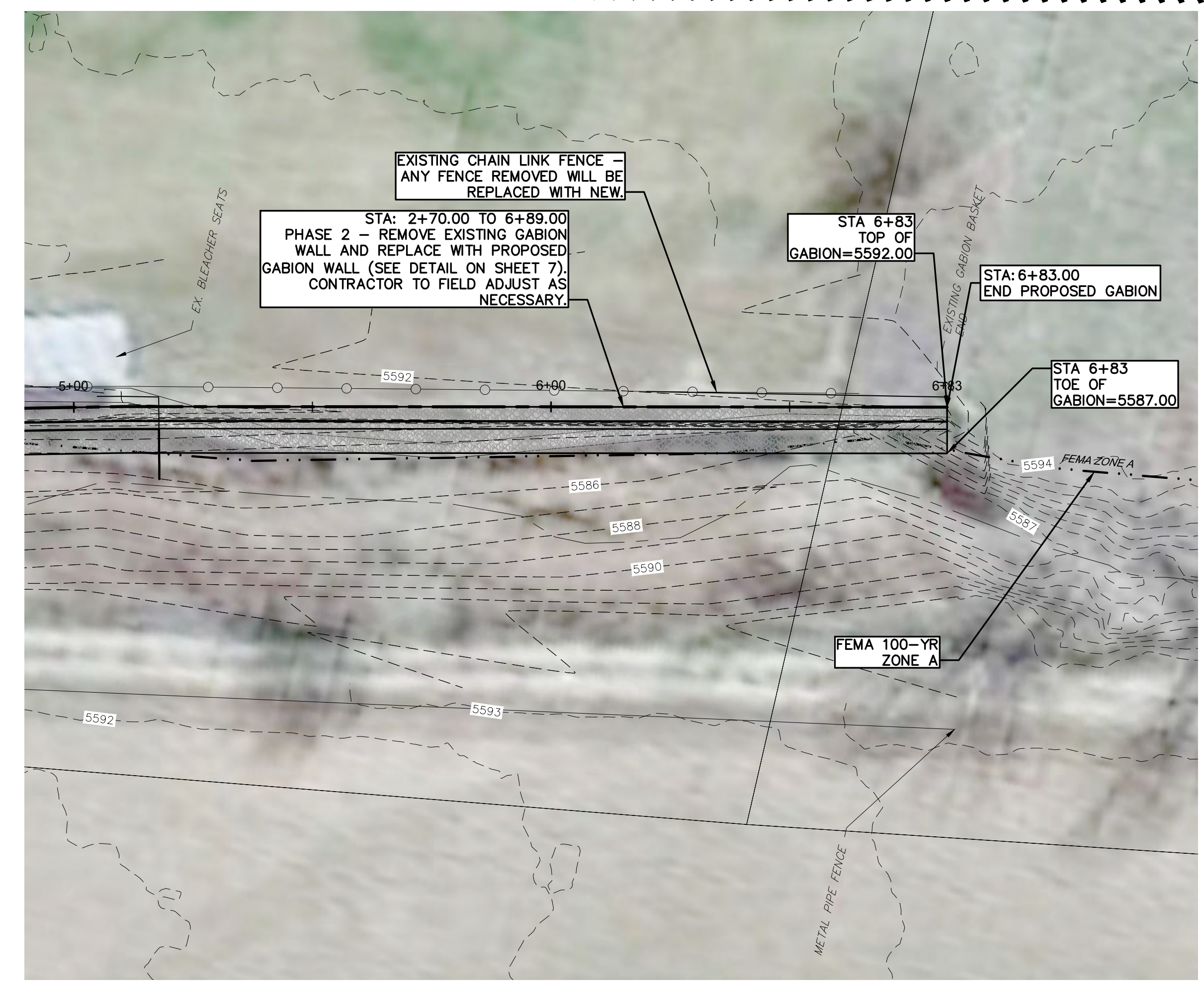

LEGEND

- 452 - EXISTING CONTOUR
- 552 - PROPOSED CONTOUR
- ↑ FLOW ARROW

- NOTES:**
- CONTRACTOR SHALL SECURE NEW GABIONS TO EXISTING UNDISTURBED ADJACENT GABIONS USING TYPICAL TIES.
 - CONTRACTOR SHALL TRANSITION FINISH GRADING SMOOTHLY BETWEEN NEW FILL AND EXISTING GRADE.
 - CONTRACTOR SHALL ATTEMPT TO AVOID DISTURBING EXISTING CURB AND PAVEMENT IF SAFELY POSSIBLE.

STA OF BACK OF GABION WALL	NORTHING	EASTING
1+00	2117688.83	2672302.28
2+00	2117590.17	2672286.51
2+42	2117548.40	2672282.37
3+00	2117490.58	2672287.19
3+14	2117476.65	2672288.48
4+75	2117320.38	2672327.25
6+83	2117117.79	2672374.34

AquaStrategies
Water Planning, Science & Engineering

Aqua Strategies Inc.
13341 W. US Hwy 290, Bldg. 2
Dripping Springs, TX 78620-5000
www.aquastrategies.com
(512) 826-2604

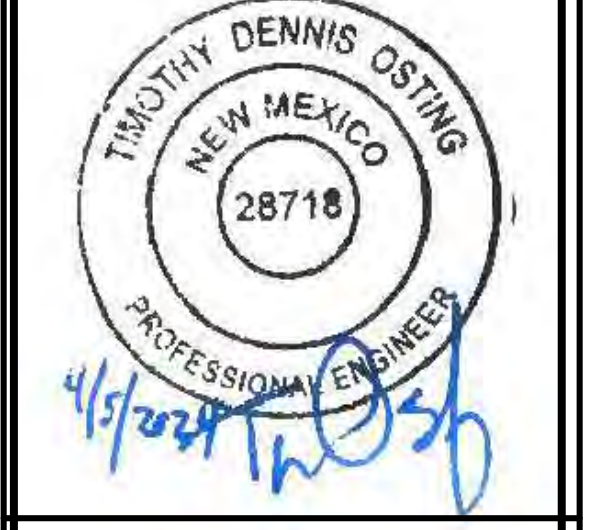

PLAN AND PROFILE

BANK STABILIZATION

WILLIAMS ARROYO HARTMAN PARK

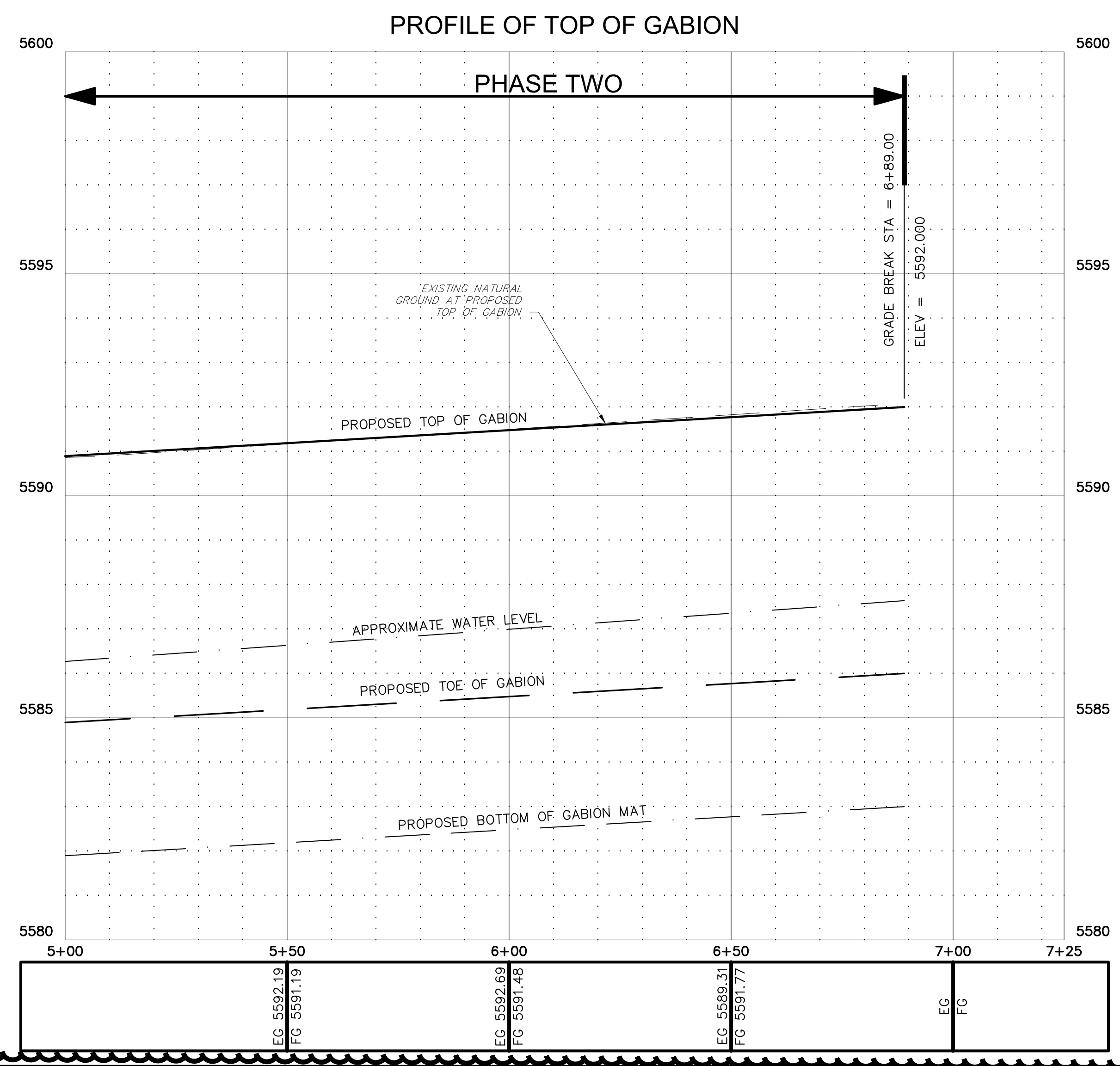

NO.	REVISION DESCRIPTION	DATE

DATE: **APRIL 5, 2024**

DESIGNED BY: **GC TDO**

DRAWN BY: **RT-MEI**

REVIEWED BY: **TDO**

SHEET

#

5

SECTION SCALE
 1"=10' HORIZONTAL
 1"=5' VERTICAL

EXCLUDED AREA
 NOT PART OF BID
 FOR PHASE 1

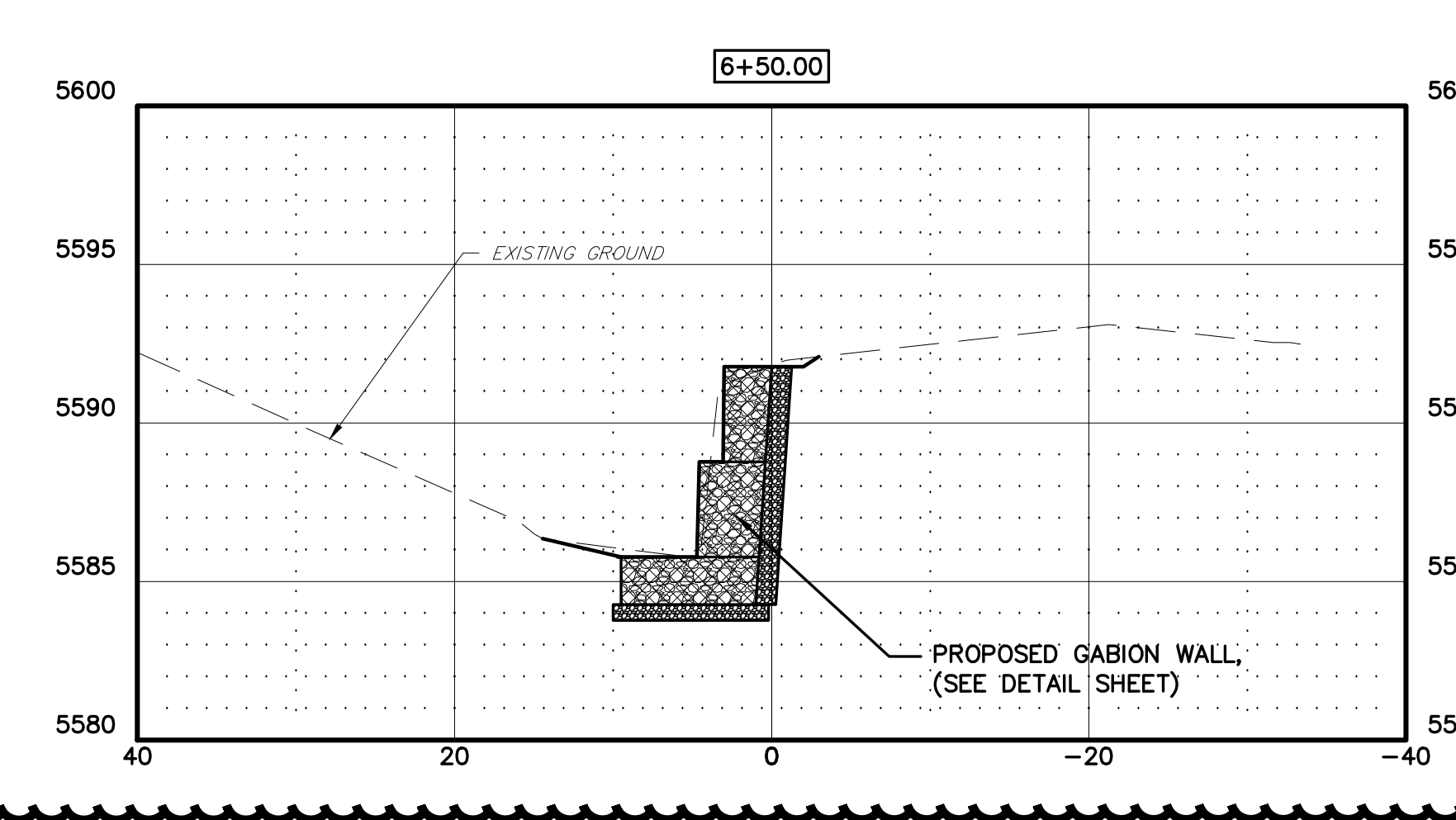
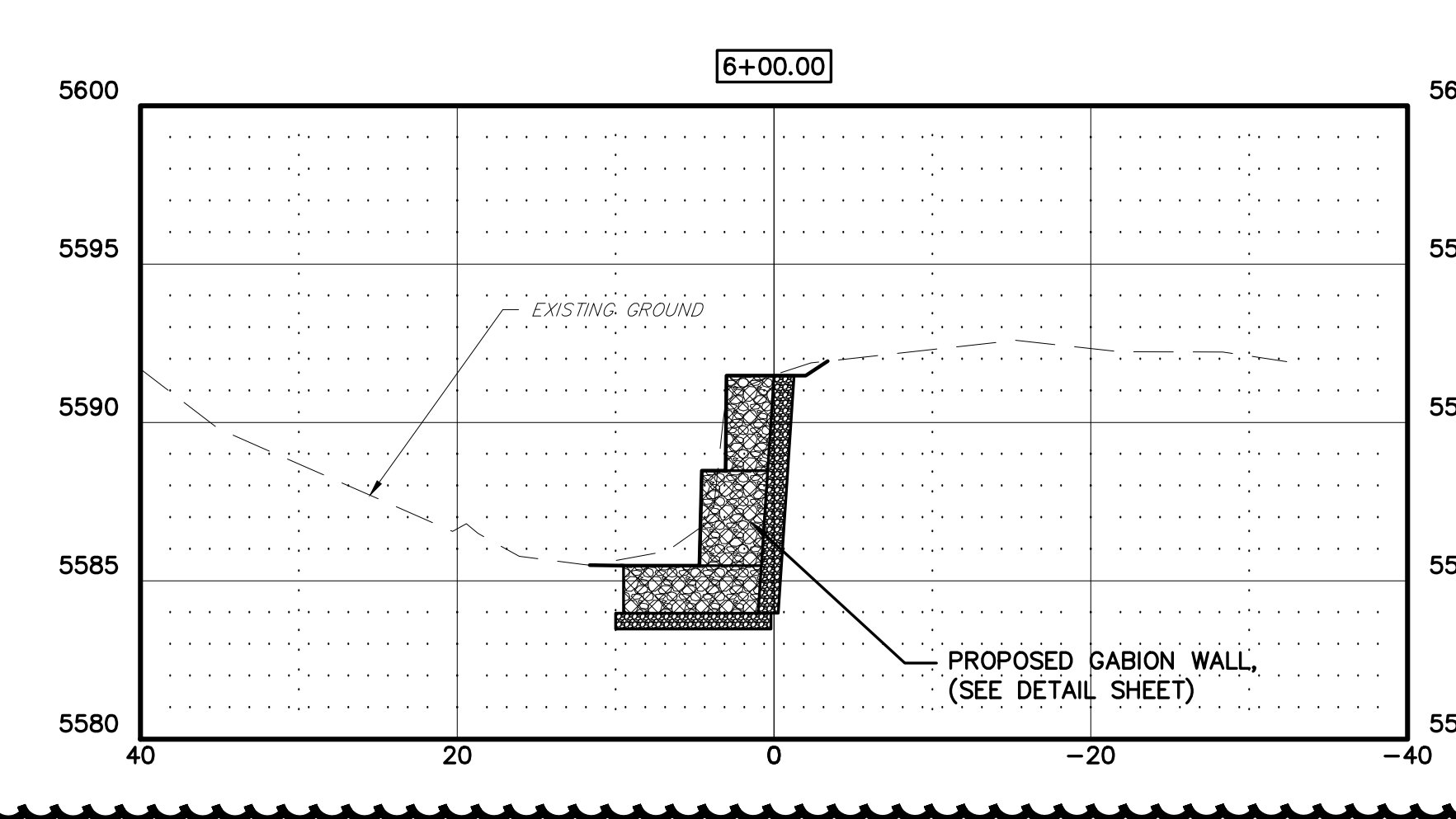
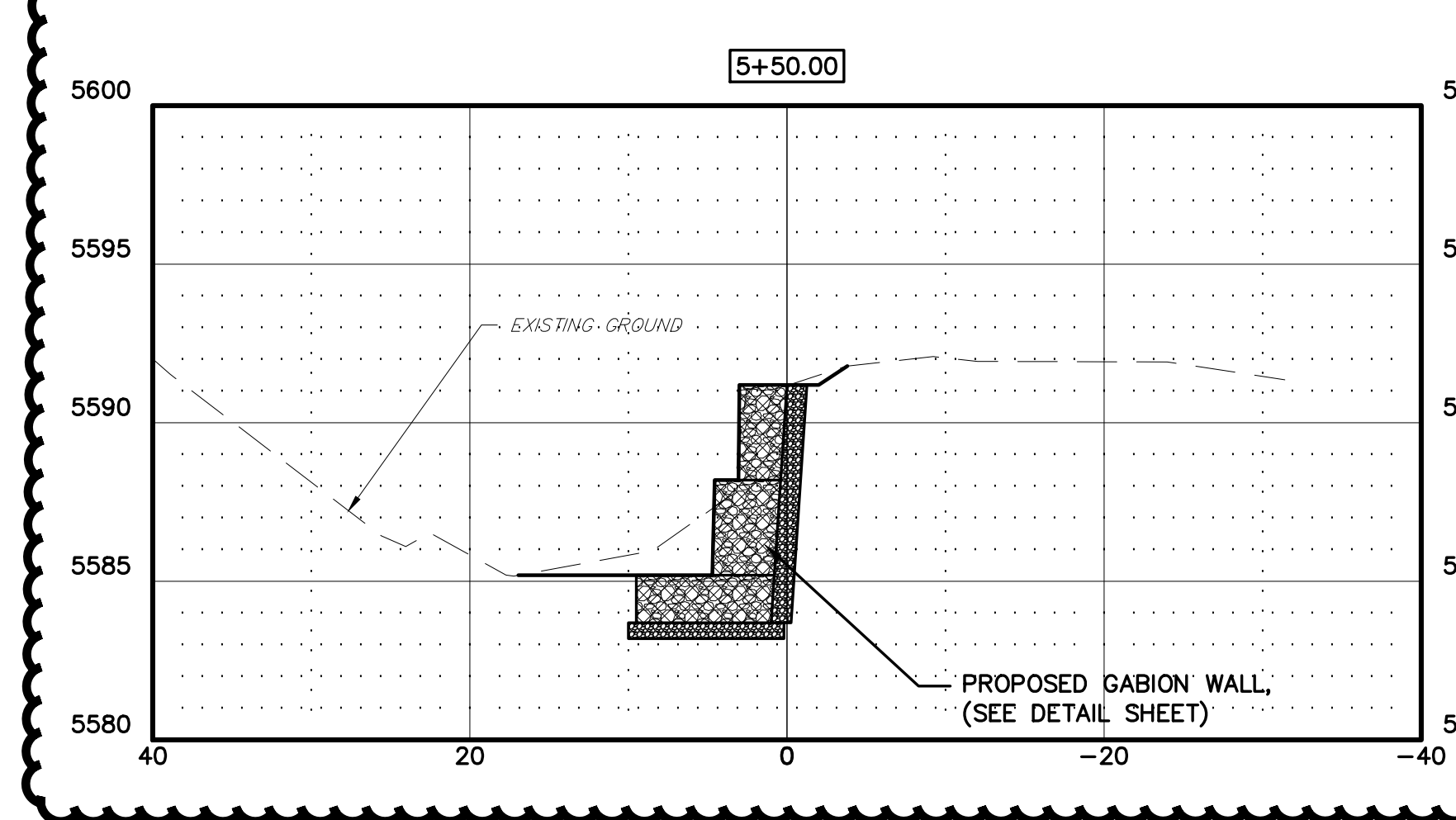
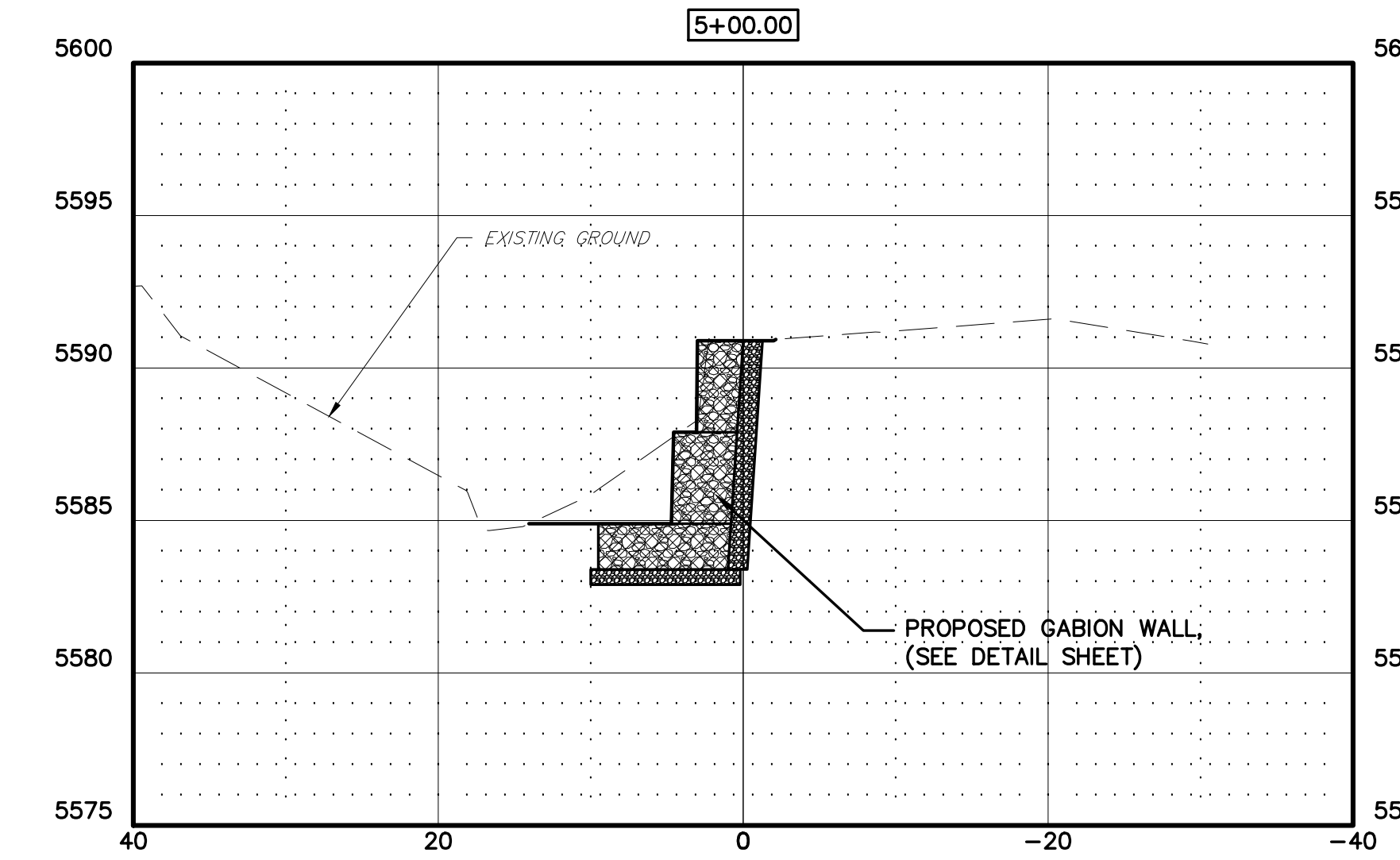
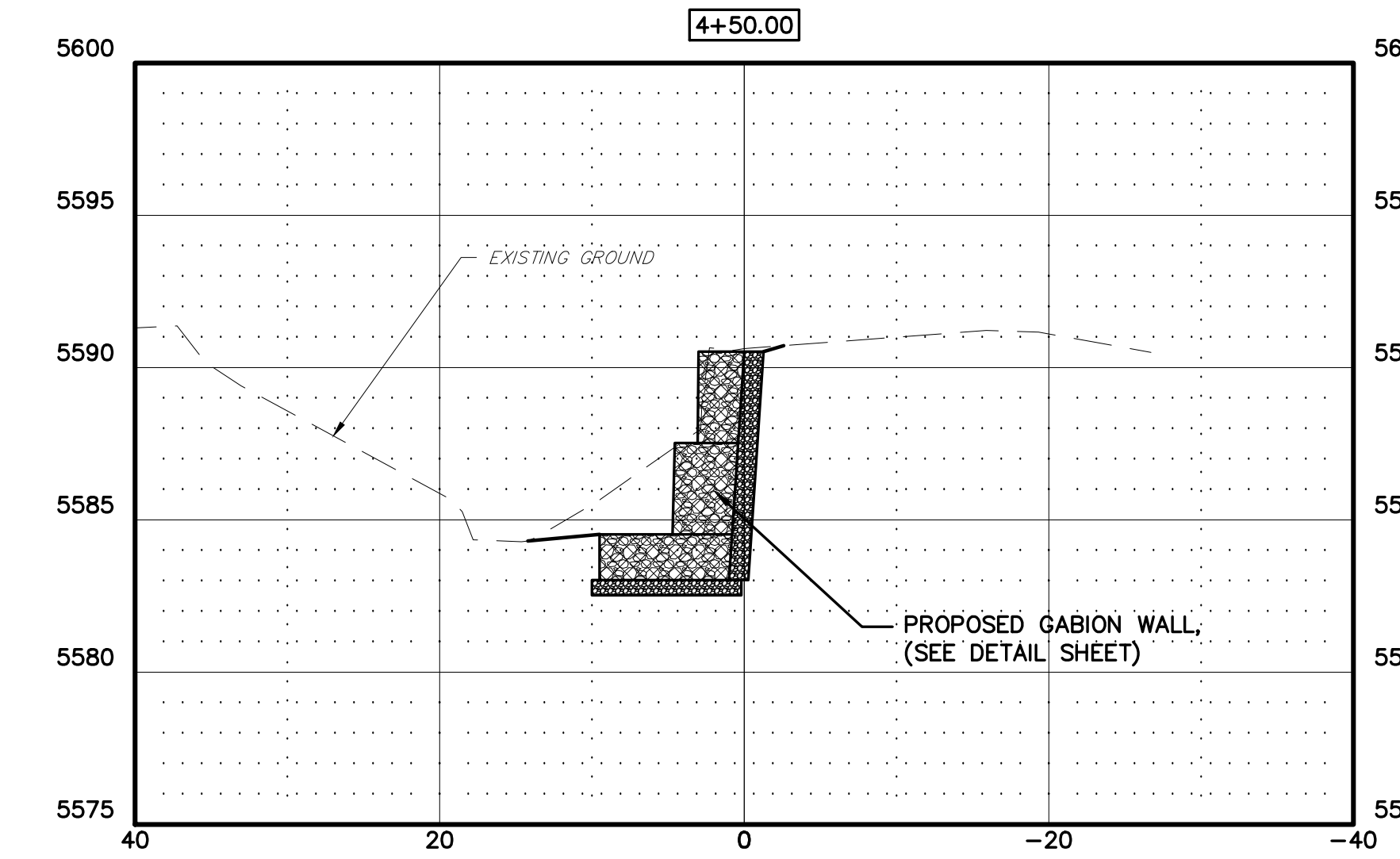
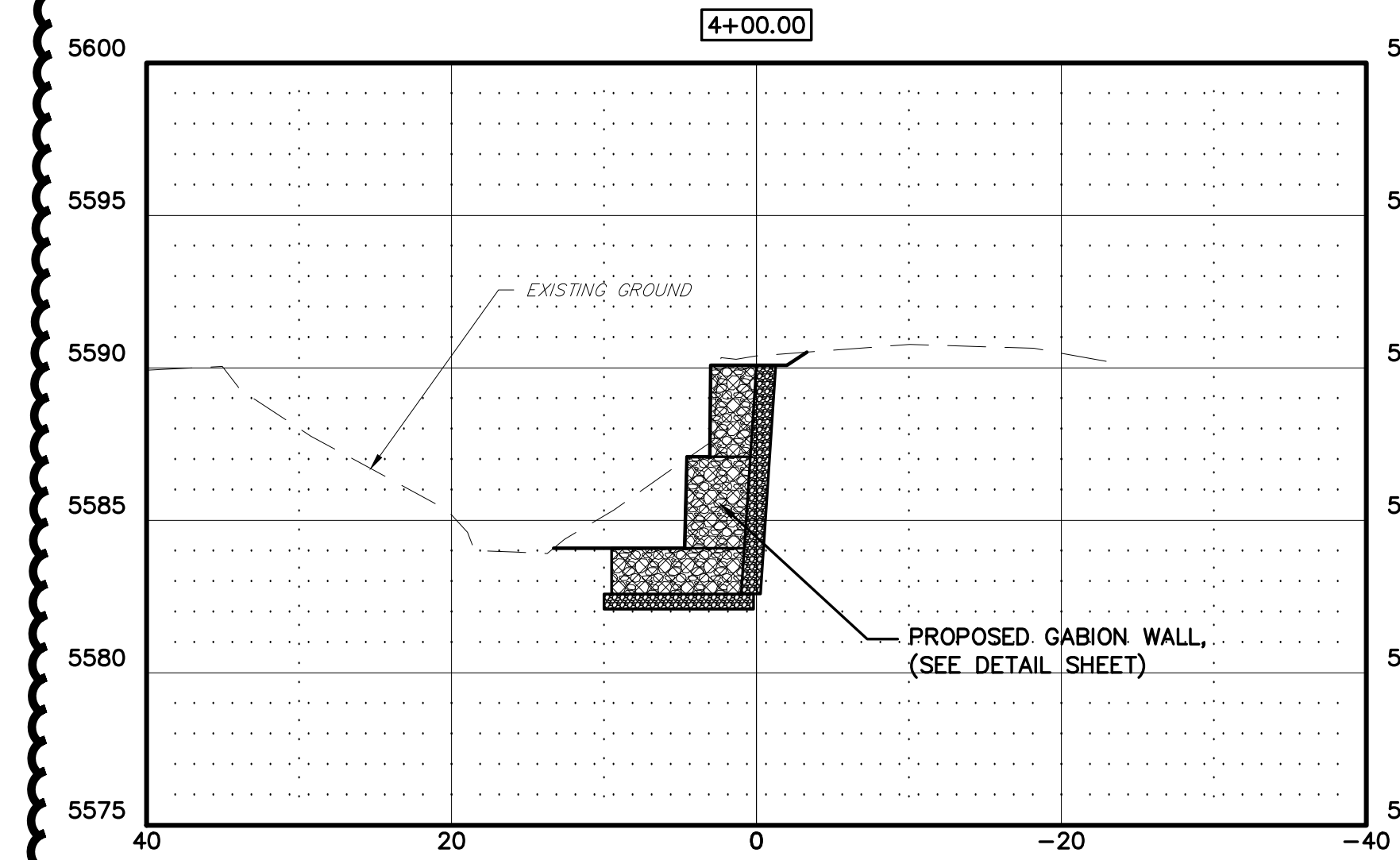
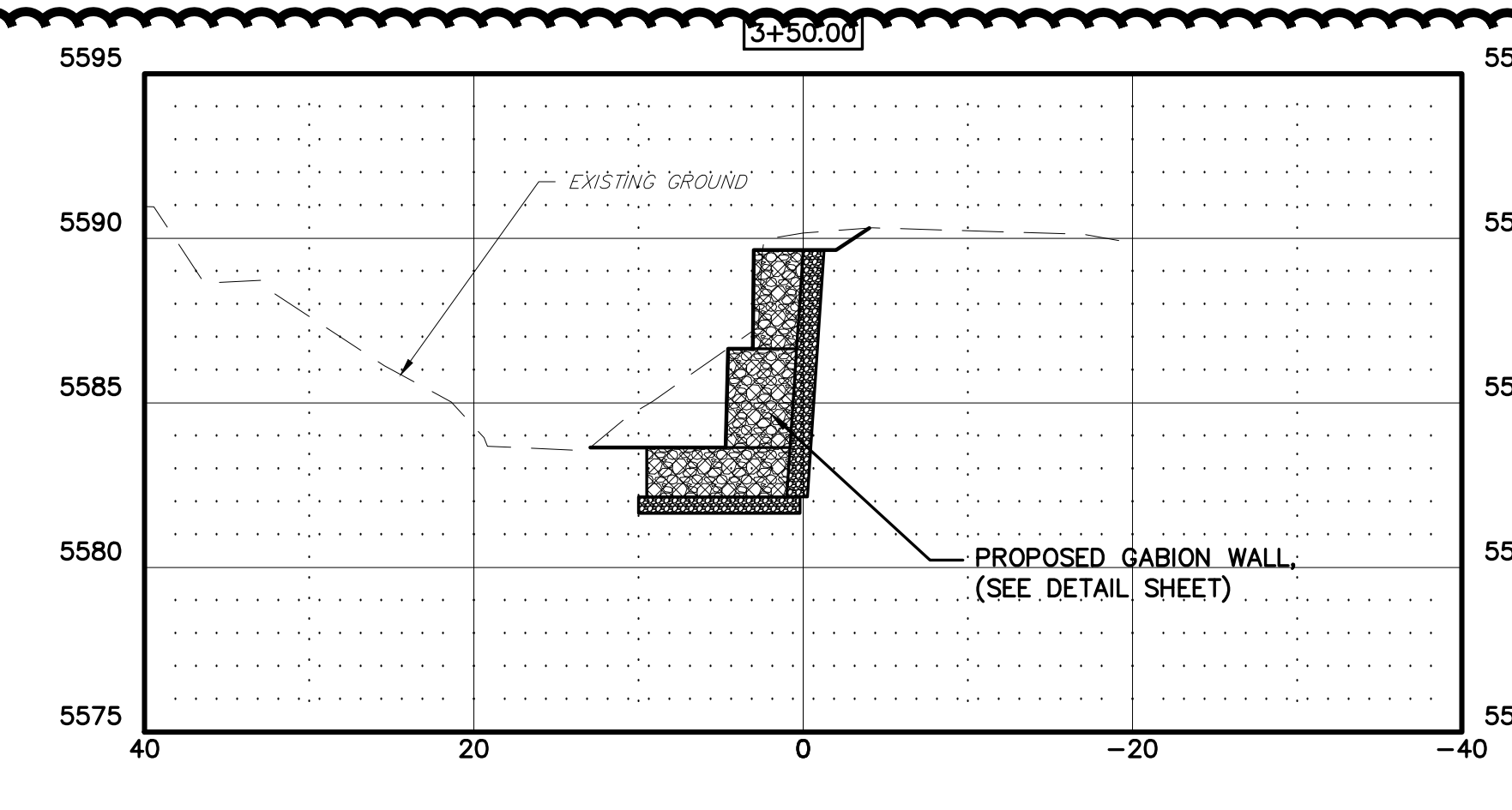
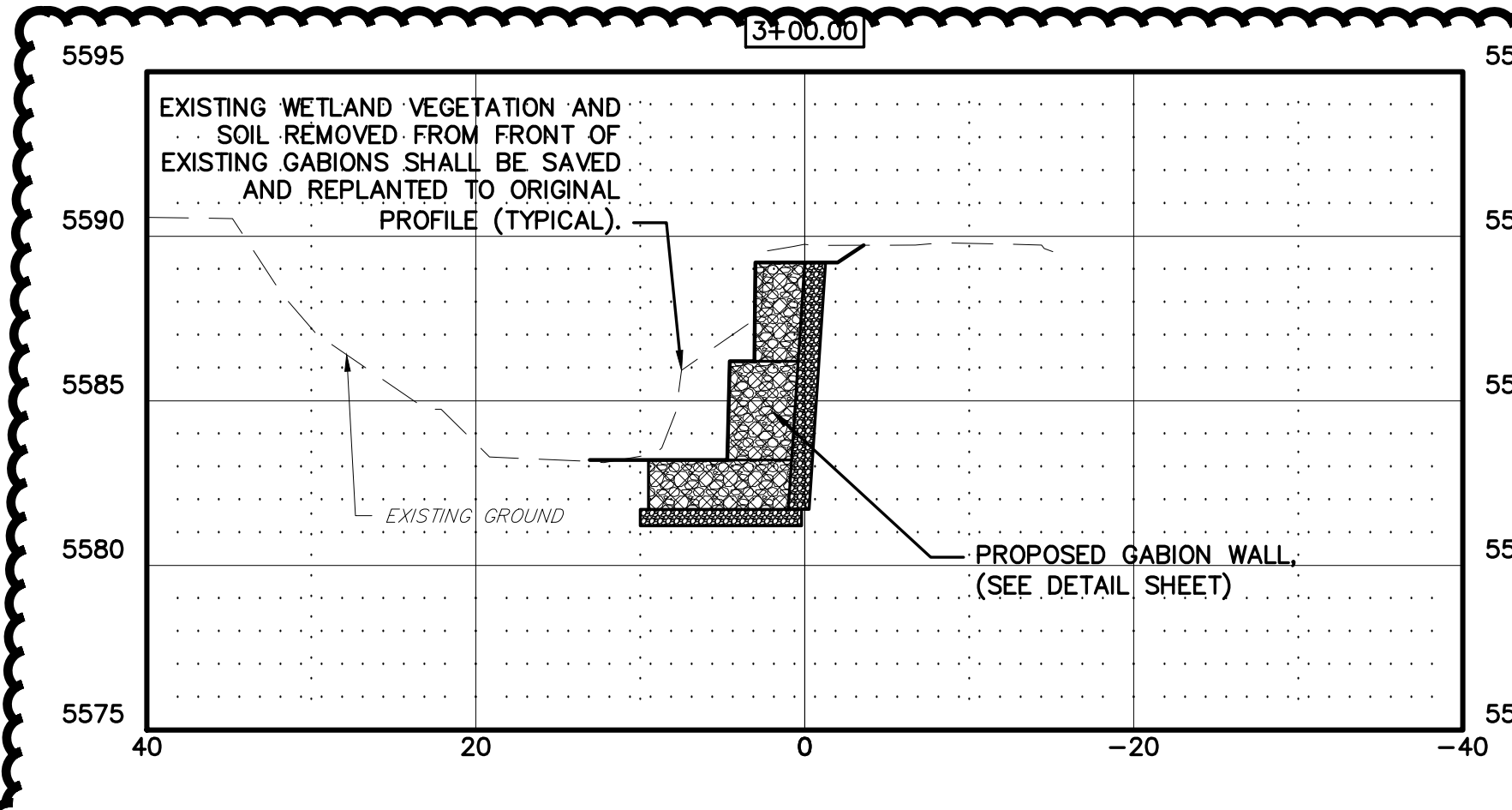
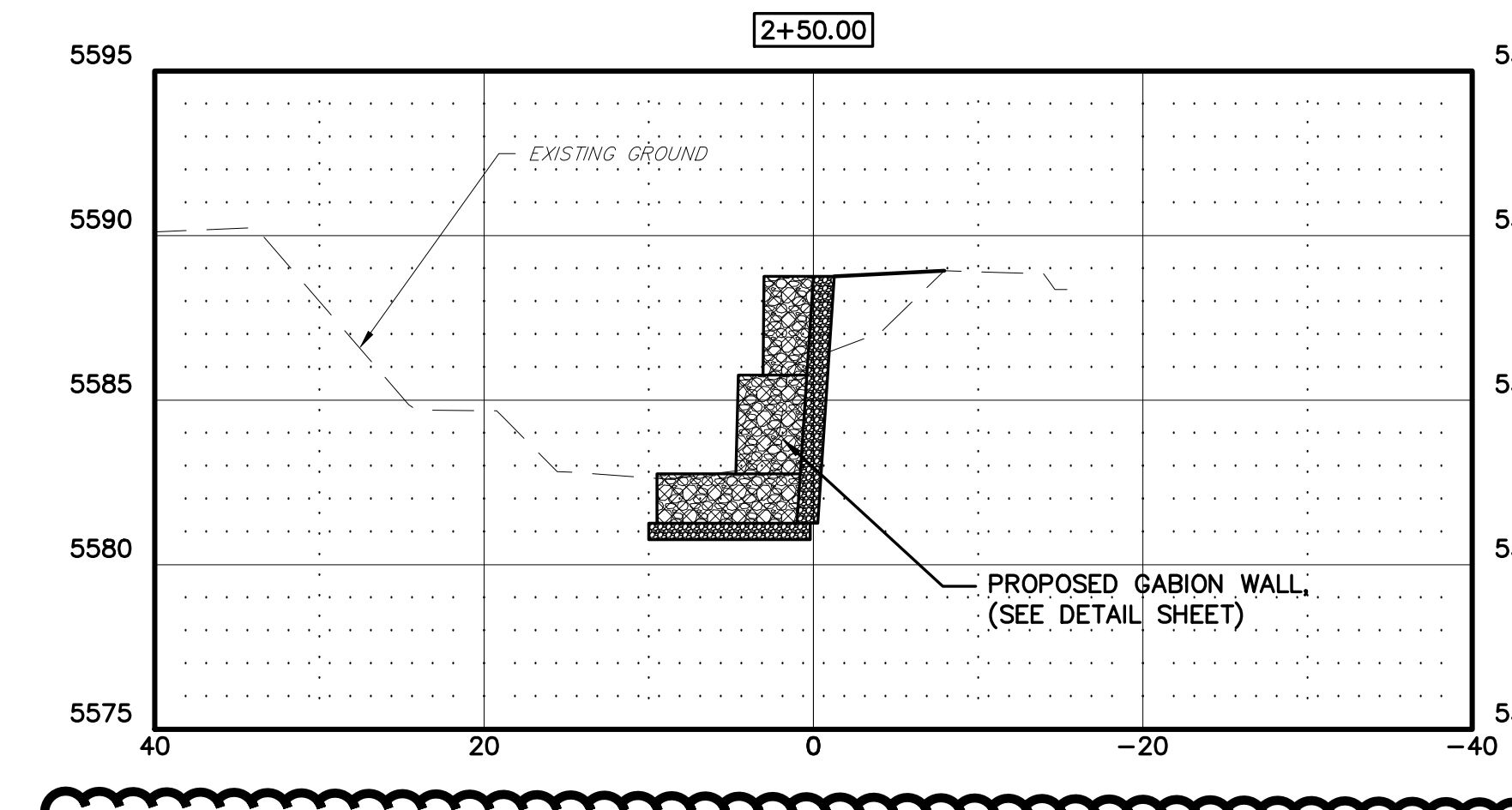
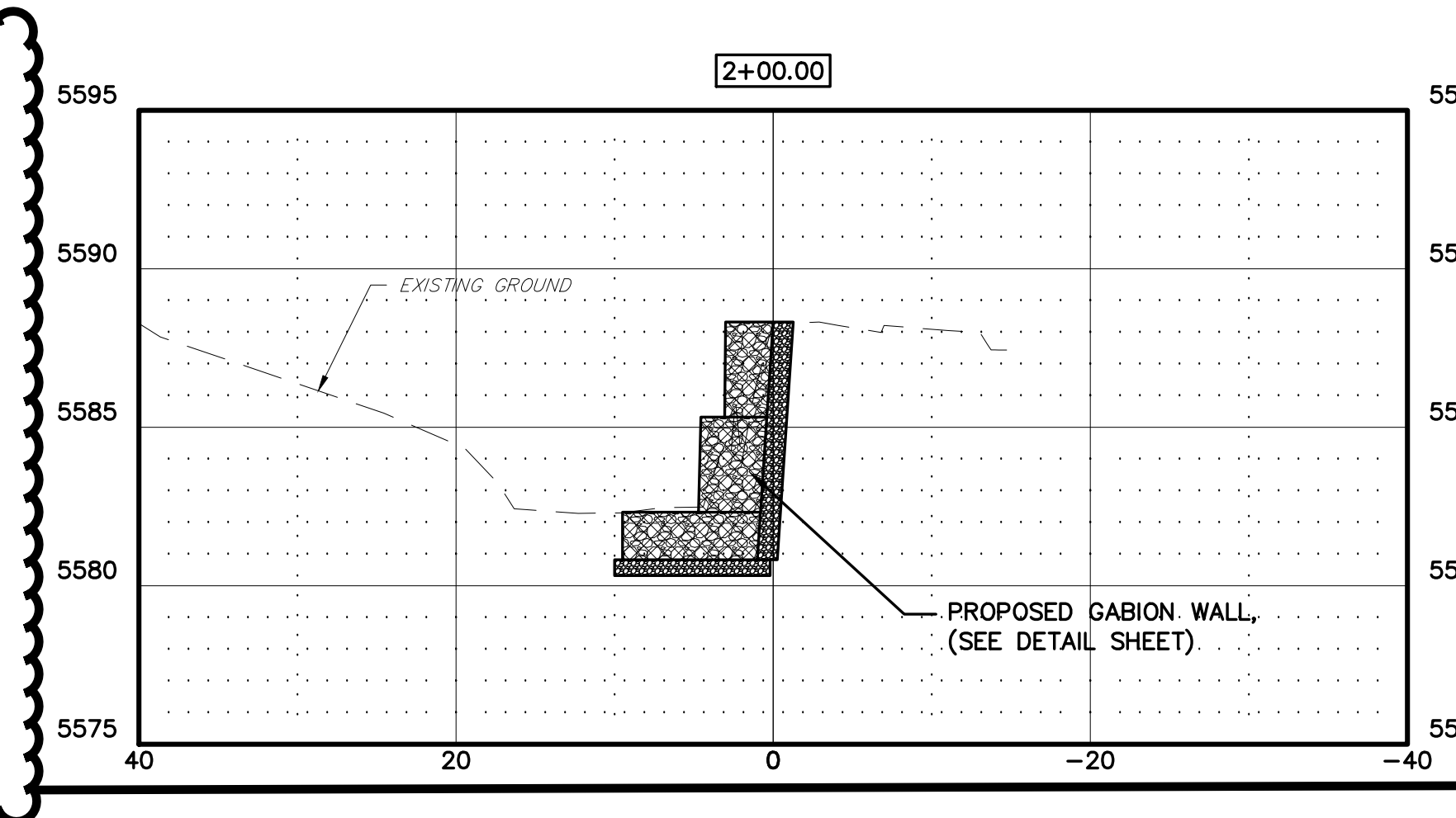
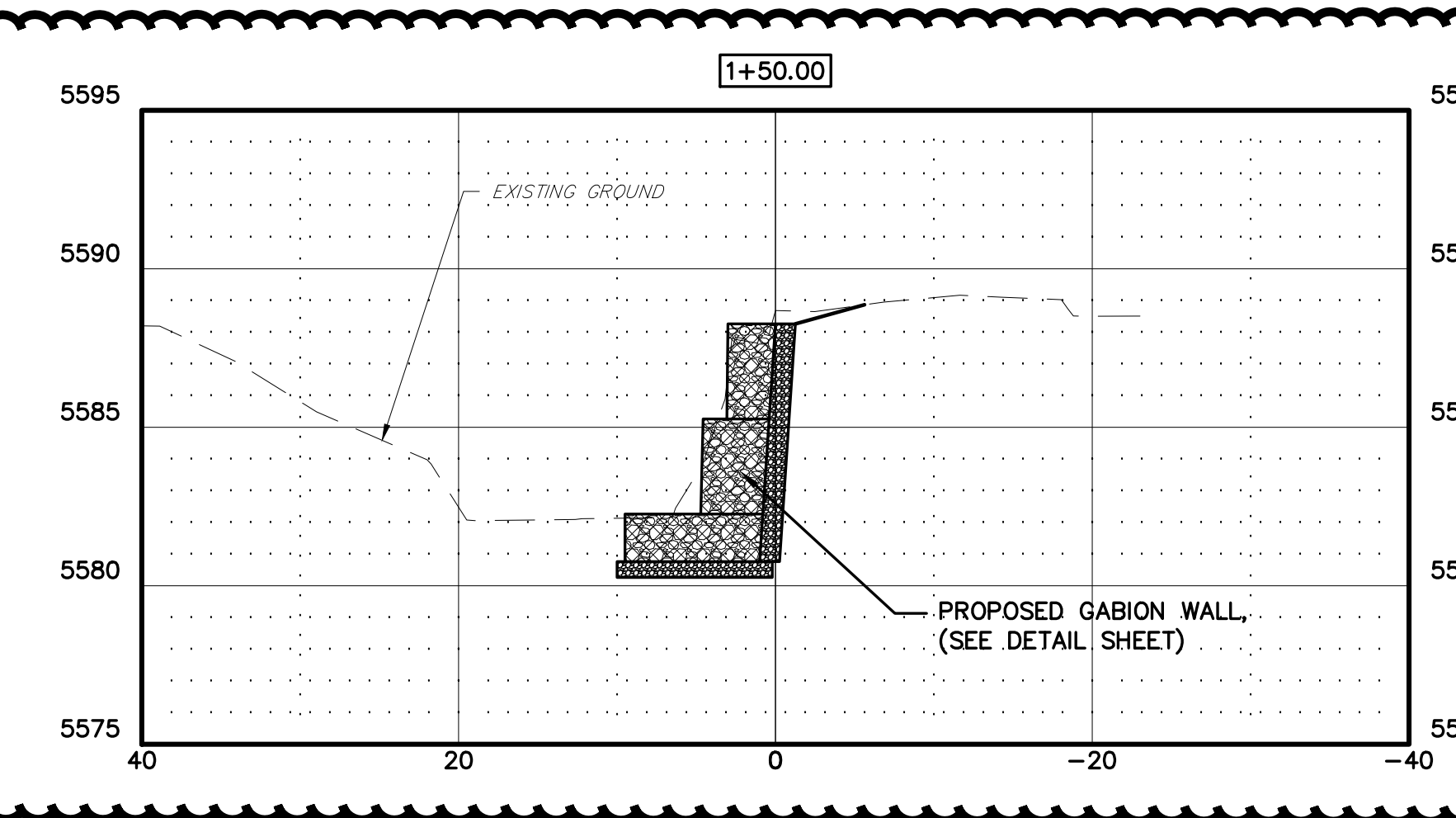
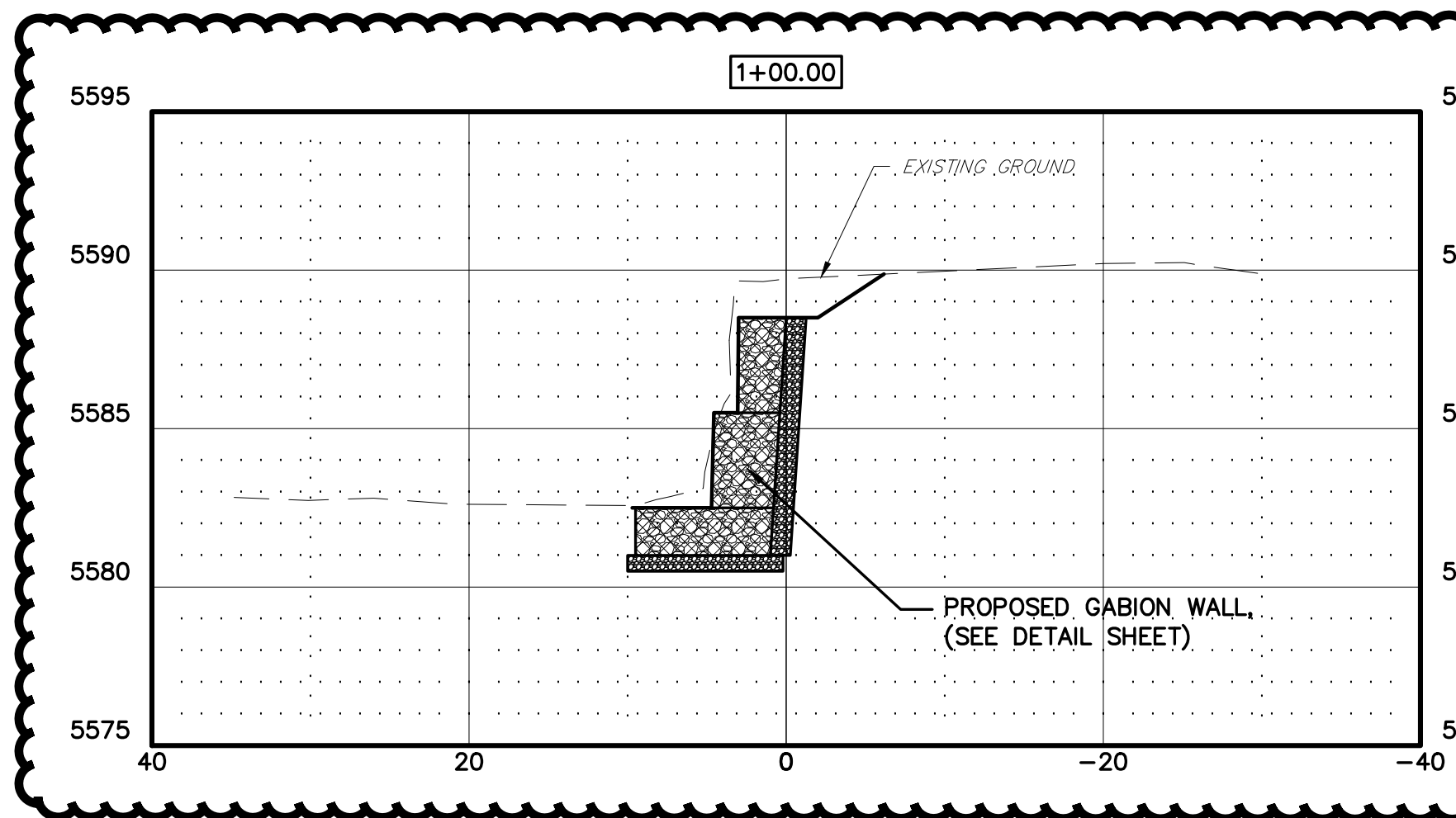

AquaStrategies
 Water Planning, Science & Engineering
 Aqua Strategies Inc.
 13341 W. US Hwy 290, Bldg. 2
 Dripping Springs, TX 78620-5000
 www.aquastrategies.com
 (512) 826-2604

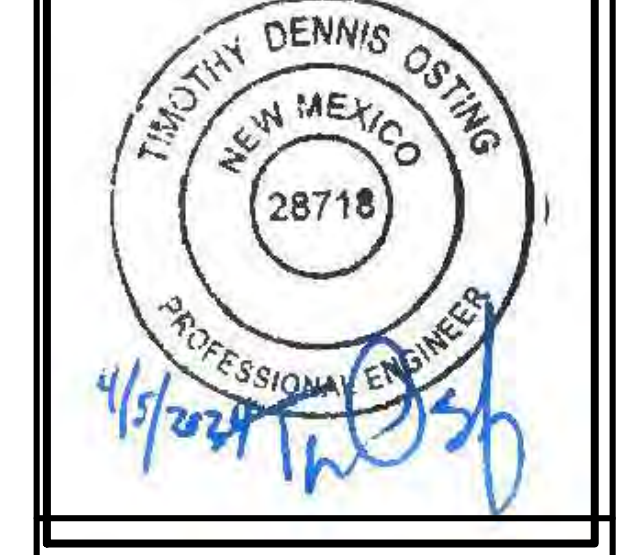

CROSS SECTIONS
BANK STABILIZATION
WILLIAMS ARROYO HARTMAN PARK

NO.	REVISION DESCRIPTION	DATE

DATE: APRIL 5, 2024
 DESIGNED BY: GC TDO
 DRAWN BY: RT-MEI
 REVIEWED BY: TDO

SHEET
#
6

CITY CONTRACTS

REFERENCE FOR OTHERS

CONSTRUCTION STANDARDS
STANDARD No. D-301 SHEET 1 OF 1

CITY OF AZTEC
PUBLIC WORKS DEPARTMENT

CITY CONTRACTS

REFERENCE FOR OTHERS

CONSTRUCTION STANDARDS
STANDARD No. D-313 SHEET 1 OF 1

CITY OF AZTEC
PUBLIC WORKS DEPARTMENT

CITY CONTRACTS

REFERENCE FOR OTHERS

CONSTRUCTION STANDARDS
STANDARD No. D-623 SHEET 1 OF 1

CITY OF AZTEC
PUBLIC WORKS DEPARTMENT

CITY CONTRACTS

REFERENCE FOR OTHERS

CONSTRUCTION STANDARDS
STANDARD No. D-624 SHEET 1 OF 1

CITY OF AZTEC
PUBLIC WORKS DEPARTMENT

CONSTRUCTION STANDARDS
STANDARD No. D-624 SHEET 1 OF 1

CITY OF AZTEC
PUBLIC WORKS DEPARTMENT

CITY CONTRACTS

REFERENCE FOR OTHERS

CONSTRUCTION STANDARDS
STANDARD No. D-622 SHEET 1 OF 1

CITY OF AZTEC
PUBLIC WORKS DEPARTMENT

CITY CONTRACTS

REFERENCE FOR OTHERS

CONSTRUCTION STANDARDS
STANDARD No. D-625 SHEET 1 OF 1

CITY OF AZTEC
PUBLIC WORKS DEPARTMENT

CITY CONTRACTS

REFERENCE FOR OTHERS

CONSTRUCTION STANDARDS
STANDARD No. D-305 SHEET 1 OF 1

CITY OF AZTEC
PUBLIC WORKS DEPARTMENT

CITY CONTRACTS

REFERENCE FOR OTHERS

CONSTRUCTION STANDARDS
STANDARD No. D-404 SHEET 1 OF 2

CITY OF AZTEC
PUBLIC WORKS DEPARTMENT

CITY CONTRACTS

REFERENCE FOR OTHERS

PIPE SIZE (DIA.)	DIMENSIONS				APPROXIMATE QUANTITIES			
	L	B	H	W	CONC.	REIN. STEEL	SOIL EXCAVATION (CY)	REIN. STEEL (LBS)
12	8	4'-0"	6'-2 3/4"	1'-6"	1.60	83	0.71	38
15	8	4'-6"	6'-5 3/4"	1'-6"	1.72	118	0.73	44
18	8	5'-0"	7'-3 1/4"	1'-6"	2.00	133	0.82	49
21	9	5'-6"	7'-8 3/4"	1'-6"	2.39	150	1.09	55
24	9	6'-0"	8'-11 1/8"	2'-0"	2.79	182	1.35	74
27	9	6'-6"	9'-9"	2'-0"	3.15	201	1.58	80
30	10	7'-0"	10'-7"	2'-0"	3.81	231	1.93	100
36	10	8'-0"	12'-2 7/8"	2'-0"	4.65	288	2.51	130
42	10	9'-0"	13'-10 11/16"	2'-0"	5.81	330	3.19	164
48	11	10'-0"	15'-8 9/16"	2'-0"	7.02	404	4.11	202
54	11	11'-0"	17'-2 7/16"	2'-0"	8.25	468	4.96	242
60	12	12'-0"	18'-10 1/4"	2'-0"	10.16	540	6.11	287
72	12	14'-0"	22'-2"	2'-0"	12.84	650	7.69	344

CONSTRUCTION STANDARDS
STANDARD No. D-404 SHEET 2 OF 2

CITY OF AZTEC
PUBLIC WORKS DEPARTMENT

CITY CONTRACTS

REFERENCE FOR OTHERS

CONSTRUCTION STANDARDS
STANDARD No. D-404 SHEET 2 OF 2

CITY OF AZTEC
PUBLIC WORKS DEPARTMENT

AquaStrategies
Water Planning, Science & Engineering

Aqua Strategies Inc.
13341 W. US Hwy 290, Bldg. 2
Dripping Springs, TX 78620-5000
www.aquastrategies.com
(512) 826-2604



DETAIL SHEET
BANK STABILIZATION
WILLIAMS ARROYO HARTMAN PARK

NO.	DATE	REVISION DESCRIPTION
1	1/7/2025	Update Typical Gabion Wall Section

DATE: APRIL 5, 2024
DESIGNED BY: GC TDO
DRAWN BY: RT-MEI
REVIEWED BY: TDO

SHEET # 7