

February 29, 2024

**Denver Dewees**

Electric Department Director  
402 S. Light Plant Road  
Aztec, NM 87410  
ddewees@aztecnm.gov

RE: Hartman Park Foundation Review  
GEOMAT Project No. 244-4807

As per your request, GEOMAT has reviewed the proposed drilled pier foundation designed by the Sadler Group sealed and dated 2/13/24 using the information GEOMAT provided in the attached geotechnical report for the Williams Arroyo Gabion Wall Repair Project #232-4570 dated October 30, 2023. Two of the proposed lights are located in the vicinity of Bores B-1 and B-2 from the referenced report. Loads and reactions provided by the Sadler Group were utilized for the review.

Based upon our analysis, it was determined that the foundations as designed by the Sadler Group will be satisfactory based upon the conditions encountered in our borings. For our analysis, we assumed that the gabion slope stabilization will be in place to resist potential blowout and scouring. We further recommend that the lights/foundations should be constructed no closer than ten (10.0) feet from the back face of the gabion retaining wall. It is assumed if there is geofabric designed for the proposed gabion wall, it could potentially be located and interfere with the location at which the light/foundation is proposed. Construction and placement of the geofabric shall follow manufacturer's recommendation when there are obstructions and penetrations in the geofabric.

Based upon the boring data, it should be anticipated that soft, wet soils and potentially groundwater will be encountered. If caving occurs or "slough" from the surface falls into the borehole after placement of the reinforcement cage, the reinforcement cage shall be removed, the bottom cleaned out, and reinforcement cage reinserted. The use of drilling slurry or casing may be required should groundwater be encountered. Tremie methods of concrete placement as described below may aid in constructing the shaft.

- Drilled shafts shall be cleaned with a clean-out bucket, immediately before concrete placement.
- The tremie or pump pipe shall have watertight joints.
- During the initial concrete placement, the concrete tremie or pump pipe shall be extended to the bottom of the drilled shaft before concrete placement.

- During placement of concrete, the bottom of the pipe shall be maintained below the top of the concrete at all times. If the seal is lost, the pipe shall be re-inserted, and the operation restarted.
- Sufficient embedment of the tremie or pump pipe in concrete shall be maintained throughout concrete placement to prevent re-entry of water. The minimum embedment depth shall be 5 feet.
- The first-placed portion of concrete flow that comes to the top of the shaft shall be wasted, as determined by the Geotechnical Engineer.
- Under no circumstances shall concrete be allowed to free fall through water or drilling fluid.

We have appreciated being of service to you on this project. If you have any questions concerning this report, please do not hesitate to contact us.

Respectfully submitted,  
GEOMAT Inc.

Greta Y. Quintana, P.E.  
Project Manager



A blue ink handwritten signature of Matthew J. Cramer.

Matthew J. Cramer, P.E.  
Principal

Copies to: Addressee

Attachment: GEOMAT Project No. 232-4570 dated October 30, 2023

# Appendix A

**GENERAL NOTES:**

1. DRILLED PIERS HAVE BEEN DESIGNED IN ACCORDANCE TO THE 2015 INTERNATIONAL BUILDING CODE, ASCE7-10 AND ACI BUILDING CODE 318-14.
2. DESIGN WIND PRESSURE ARE BASED ON A  $V_{BASIC} = 110$  MPH WIND SPEED (85 MPH BASIC WIND SPEED,  $V_{ASD}$ ) AND PER AASHTO LTS6 2013.
3. DRILLED PIER DESIGNED BASED ON THE REACTIONS (SERVICES) PROVIDED BY MSM MAKERS. LIGHT POLES ARE DESIGNED FOR:

50' POLE	MOMENT	=33.8 K-FT
	HORIZONTAL	=0.8675 K
	AXIAL	=1.4331 K

4. CONCRETE SHALL HAVE A MINIMUM COMPRESSIVE STRENGTH OF 3,000 PSI AT 28 DAYS.
5. DRILLED PIERS DESIGNS ARE BASED ON ASSUMED VALUES FROM THE GEOTECHNICAL ENGINEERING REPORT BY GEOMAT INC DATED 11-30-2023 PROJECT NO: 2324570 SOIL CLASSIFICATION. ASSUMED DESIGN VALUES FROM IBC 2015 ARE AS FOLLOWS:

ALLOWABLE END BEARING PRESSURE .....2,000 PSF  
 ASSUMED INTERNAL ANGLE OF FRICTION.....32 DEG  
 ASSUME LATERAL PRESSURE .....150 PSF/FT

6. CONTRACTOR SHOULD ENGAGE WITH THE GEOTECHNICAL-ENGINEER-OF-RECORD (GER) IN THE REVIEW OF THIS FOUNDATION IN ORDER TO PROVIDE ANY ADDITIONAL GEOTECHNICAL RECOMMENDATIONS. OBSERVATIONS DURING PIER DRILLING SHOULD INCLUDE, BUT NOT NECESSARILY BE LIMITED TO, THE FOLLOWING ITEMS:

- VERIFICATION OF PROPER BEARING STRATA AND CONSISTENCY OF SUBSURFACE STRATIFICATION WITH REGARD TO BORING LOGS.
- PROPER HANDLING OF ANY OBSERVED WATER SEEPAGE AND SLOUGHING OF SUBSURFACE MATERIALS,
- NO MORE THAN 2 INCHES OF STANDING WATER SHOULD BE PERMITTED IN THE BOTTOM OF PIER HOLES.
- BASED ON AVAILABLE INFORMATION FROM THE GEOTECHNICAL REPORT, HYDROSTATIC GROUNDWATER LEVELS ARE AT OR NEAR THE PROPOSED STRUCTURES AND RECOMMENDED CORRECTIONS FOR THE NEW TRACK AND SYNTHETIC TURF FIELDS.

INFORMATION REGARDING GROUNDWATER MEASUREMENTS CAN BE FOUND ON THE BORING LOGS IN THE RESULTS OF THE GEOTECHNICAL REPORT MENTIONED HERE IN.

7. CONTRACTOR SHALL MAINTAIN HOLE SIDEWALLS STABILITY DURING DRILLING. REMOVE LOOSE MATERIAL AND KEEP EXCAVATION FREE OF WATER. PROVIDE ANY MEANS TO MAINTAIN THE DRILLED HOLE DRY. REFER TO ACI 336.3R-93 CHAPTER 4 FOR CONSTRUCTION METHODS. PLACE CONCRETE AS SOON AS PRACTICAL AFTER COMPLETION OF EXCAVATION AND THE CONDITIONS HAVE BEEN ACCEPTED BY OWNER'S REPRESENTATIVE-GEOTECHNICAL ENGINEER.

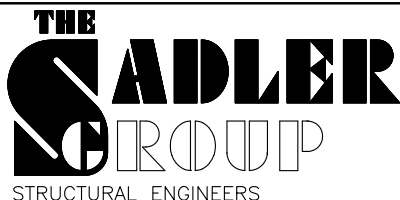

500 MAIN ST. • SUITE 700  
 FORT WORTH, TEXAS 76102  
 PHONE: 817-332-1074  
 tom@thesadlergroup.com

**CLIENT:**  
 MAKER SALES AND MARKETING, LLC  
 PO BOX 14537  
 HALTOM CITY, TX 76117

**PROJECT:**  
 HARTMAN SOCCER FIELDS  
 W. AZTEC BOULEVARD  
 AZTEC, NM 87410

**PRODUCT:**  
 LIGHT POLES PIERS

**PROJECT NO.**  
 24-109

**DATE:**  
 02-13-2024

**DRAWN BY:**  
 VNR

**SHEET NO.**

50

EPA=15 FT<sup>2</sup>

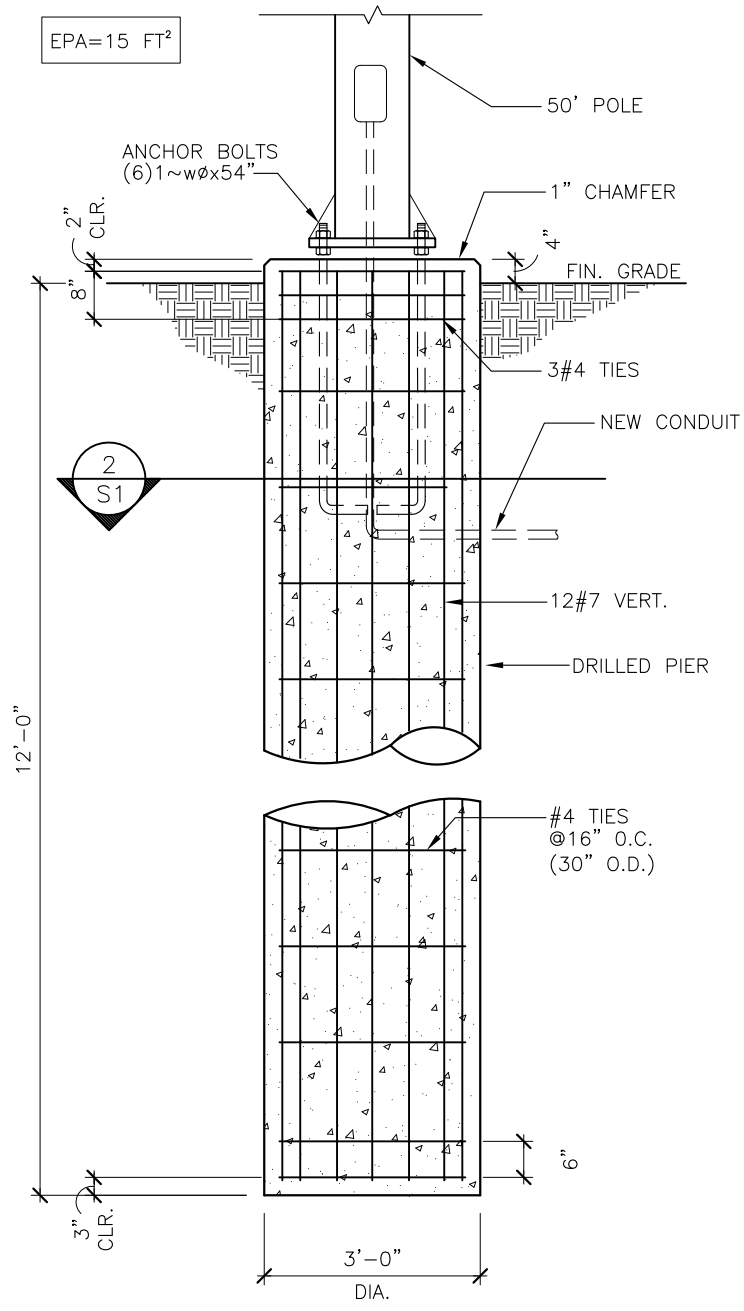

2  
S1

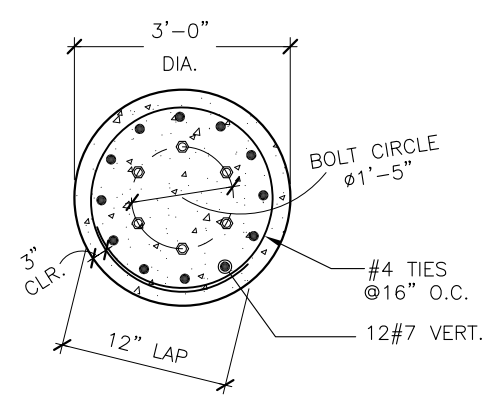

2 SECTION  
SCALE: 3/8"=1'-0"

1 POLE PIER  
SCALE: 3/8"=1'-0"

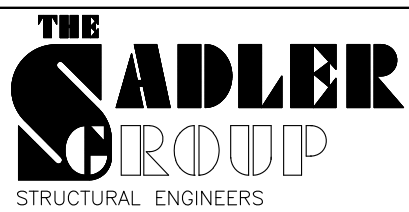

500 MAIN ST. • SUITE 700  
FORT WORTH, TEXAS 76102  
PHONE: 817-332-1074  
tom@thesadlergroup.com

CLIENT:  
MAKER SALES AND MARKETING, LLC  
PO BOX 14537  
HALTOM CITY, TX 76117

PROJECT:  
HARTMAN SOCCER FIELDS  
W. AZTEC BOULEVARD  
AZTEC, NM 87410

PRODUCT:  
LIGHT POLES PIERS

PROJECT NO. 24-109	DATE: 02-13-2024	DRAWN BY: VNR	SHEET NO. S1
-----------------------	---------------------	------------------	-----------------

Aztec, NM 87410, USA



# PHOTOMETRIC SUMMARY



RE-CALC

GET PDF

Aztec Skatepark





**GEOTECHNICAL ENGINEERING REPORT  
WILLIAMS ARROYO GABION WALL REPAIR  
AZTEC, NEW MEXICO**

Submitted To:

**Tim Osting, PE, D.WRE, CFM**

Aqua Strategies Inc.

13341 W. US Hwy 290, Bldg. 2

Austin, TX 78737

Submitted By:

**GEOMAT Inc.**

915 Malta Avenue

Farmington, New Mexico 87401

October 30, 2023

GEOMAT Project 232-4570



915 Malta Avenue ♦ Farmington, NM 87401 ♦ Tel (505) 327-7928 ♦ Fax (505) 326-5721

October 30, 2023

**Tim Osting, PE, D.WRE, CFM**

Aqua Strategies Inc.

13341 W. US Hwy 290, Bldg. 2

Austin, TX 78737

RE: Geotechnical Engineering Report  
Willaims Arroyo Gabion Wall Repair  
Aztec, New Mexico  
GEOMAT Project No. 232-4570

GEOMAT Inc. (GEOMAT) has completed the geotechnical engineering exploration for the Williams Arroyo Gabion Wall Repair project located at the Hartman Soccer Fields in Aztec, New Mexico. This study was performed in general accordance with our Proposal No. 232-06-18 – Rev. 1, dated August 14, 2023.

The results of our engineering study, including the geotechnical recommendations, vicinity plan, boring records, and laboratory test results are attached. Other design and construction details, based upon geotechnical conditions, are presented in the report.

We have appreciated being of service to you in the geotechnical engineering phase of this project. If you have any questions concerning this report, please contact us.

Sincerely yours,

GEOMAT Inc.

A handwritten signature in blue ink, appearing to read "Chase J. Beckstead".

Chase J. Beckstead, P.E.  
Staff Engineer

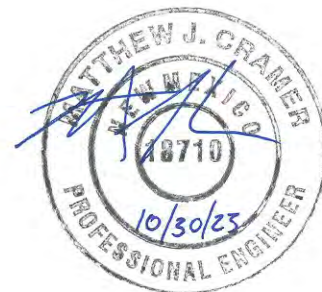

Matthew J. Cramer, P.E.  
President, Principal

Copies to: Addressee (1)



**TABLE OF CONTENTS**

	<b><u>Page No.</u></b>
<b>INTRODUCTION</b> .....	1
<b>PROPOSED CONSTRUCTION</b> .....	1
<b>SITE EXPLORATION</b> .....	1
Field Exploration .....	2
Laboratory Testing.....	2
<b>SITE CONDITIONS</b> .....	2
<b>SUBSURFACE CONDITIONS</b> .....	4
Soil Conditions.....	4
Groundwater Conditions.....	5
Laboratory Test Results .....	5
<b>OPINIONS AND RECOMMENDATIONS</b> .....	5
Geotechnical Considerations .....	5
Foundations.....	6
Corrosion.....	7
Site Classification .....	7
Lateral Earth Pressures .....	7
Slopes .....	8
Earthwork.....	8
General Considerations .....	8
Site Clearing.....	9
Excavation.....	9
Fill Materials.....	10
Placement and Compaction.....	10
Compliance .....	11
Drainage.....	11
Surface Drainage.....	11
<b>GENERAL COMMENTS</b> .....	12

**TABLE OF CONTENTS (Continued)**

**APPENDIX A**

Vicinity Plan  
Logs of Borings  
Unified Soil Classification  
Drilling and Exploration Procedures  
Photographs

**APPENDIX B**

Laboratory Test Results  
Laboratory Test Procedures

**APPENDIX C**

Important Information About This Geotechnical Engineering Report (Taken From GBA)

**GEOTECHNICAL ENGINEERING REPORT  
WILLIAMS ARROYO GABION WALL REPAIR  
AZTEC, NEW MEXICO  
GEOMAT PROJECT NO. 232-4570**

**INTRODUCTION**

This report contains the results of our geotechnical engineering exploration for the Williams Arroyo Gabion Wall Repair project located at the Hartman Soccer Fields in Aztec, New Mexico, as shown on the Vicinity Plan in Appendix A of this report.

The purpose of these services is to provide information and geotechnical engineering recommendations about:

- subsurface soil conditions
- groundwater conditions
- lateral soil pressures
- earthwork
- drainage

The opinions and recommendations contained in this report are based upon the results of field and laboratory testing, engineering analyses, and experience with similar soil conditions, structures, and our understanding of the proposed project as stated below.

**PROPOSED CONSTRUCTION**

Based upon the information provided, we understand the existing wall is approximately 6 feet high with a length of 600 linear feet. A portion of the wall has been damaged and requires repair. Based upon information received from the design team, we anticipate that the work will consist of the removal and reconstruction of the damaged sections with new gabion walls and geofabric.

**SITE EXPLORATION**

Our scope of services performed for this project included a site reconnaissance, a subsurface exploration program, laboratory testing and engineering analyses.

### **Field Exploration:**

Subsurface conditions at the site were explored on August 28<sup>th</sup>, 2023, by drilling a total of six (6) exploratory borings at the approximate locations shown on the Vicinity Plan in Appendix A. Borings B-1 through B-6 were drilled along the arroyo channel to an approximate planned depth 15 feet below existing ground surface (bgs).

The borings were advanced using a CME-55 truck-mounted drill rig with continuous-flight, 7.25-inch O.D. hollow-stem auger. The borings were continuously monitored by a staff engineer from our office who examined and classified the subsurface materials encountered, obtained representative samples, observed groundwater conditions, and maintained a continuous log of each boring.

Soil samples were obtained from the borings using a combination of standard 2-inch O.D. split spoon and 3-inch O.D. modified Dames & Moore ring barrel samplers. The samplers were driven using a 140-pound hammer falling 30 inches. The standard penetration resistance was determined by recording the number of hammer blows required to advance the sampler in six-inch increments. Representative bulk samples of the subsurface materials were also obtained.

Groundwater evaluations were made in each boring at the time of site exploration. Soils were classified in accordance with the Unified Soil Classification System described in Appendix A. Boring logs were prepared and are presented in Appendix A.

### **Laboratory Testing:**

Samples retrieved during the field exploration were transported to our laboratory for further evaluation. At that time, the field descriptions were confirmed or modified as necessary, and laboratory tests were performed to evaluate the engineering properties of the subsurface materials.

### **SITE CONDITIONS**

The proposed project site is located at Hartman Soccer Field in Aztec, New Mexico along the drainage arroyo known as Williams Arroyo. The project site is generally flat, developed with small building structures, grandstands and vegetated with grass for the athletic fields. The site is bordered by water channels on the west and north side, grass fields to the east, and a private home property to the south.

The following photograph depicts the site at the time of our exploration. Additional photographs in Appendix A are provided to illustrate the extent of damage and construction of the gabion wall.



**Drill Rig at Boring B-2  
View Towards the North**



**Damaged Gabion Wall near Boring B-3  
View Towards the North**



**Existing Gabion Wall along Animas River near Boring B-5  
View Towards the East**

## **SUBSURFACE CONDITIONS**

### **Soil Conditions:**

As presented on the Boring Logs in Appendix A, in boring B-1, we encountered grass and topsoil, underlain by sandy soil to approximately 6 feet bgs. Beneath the sandy soil we encountered clayey soil to approximately 9 feet bgs underlain by sandy and gravelly soils to the depths explored. In boring B-2, we encountered grass and topsoil, underlain by sandy soil to approximately 4 ½ feet bgs. Beneath the sandy soil, we encountered silty soil to approximately 7 feet bgs, underlain by sandy soil to approximately 12 feet bgs. Beneath the sandy soil, we encountered gravel and cobbles and terminated our boring at 14 feet bgs due to auger refusal on gravel and cobbles. In boring B-3, we encountered sandy soil to approximately 5 ½ feet bgs underlain by clayey soil to approximately 6 ½ feet bgs. Beneath the clayey soil, we encountered sandy and gravelly soils to 9 feet bgs underlain by gravel and cobbles and terminated our boring at 11 ½ feet bgs due to auger refusal on gravel and cobbles. In boring B-4, we encountered sandy and gravelly soils to approximately 8 feet bgs underlain by gravel and cobbles and terminated our boring at 10 feet bgs due to auger refusal on gravel and cobbles. In borings B-5 and B-6, we encountered gravelly soils ranging from 5 ½ to 7 feet bgs underlain terminated our borings due to auger refusal on gravel and cobbles.

The sandy soils were generally light brown to brown, gray, fine to coarse-grained, very loose to medium dense, and slightly damp to wet. The clayey soils were generally tan to brown, gray, soft to stiff, and damp to wet.

### **Groundwater Conditions:**

Groundwater was encountered in the borings B-1 through B-4 at ranging from depths of 5 ½ to 7 feet bgs at the time of our exploration. Groundwater elevations can fluctuate over time depending upon precipitation, irrigation, runoff, and infiltration of surface water. We do not have any information regarding the historical fluctuation of the groundwater level in this vicinity.

### **Laboratory Test Results:**

Laboratory analyses of samples tested indicates that the sandy soils have fines contents (silt- and/or clay-sized particles passing the U.S. No. 200 sieve) ranging from approximately 24 to 38 percent, and plasticity index ranging from non-plastic to 16. The in-place dry density of sandy soil samples ranged from approximately 97 to 104 pounds per cubic foot (pcf), with natural moisture contents ranging from approximately 10 to 17 percent.

Laboratory analyses of a sample tested indicates that the silty soil has fines contents (silt- and/or clay-sized particles passing the U.S. No. 200 sieve) of approximately 51 percent and is non-plastic. The in-place dry density of a clayey soil sample was approximately 82 pounds per cubic foot (pcf), with natural moisture contents ranging from approximately 34 percent.

A modified proctor (ASTM D1557) and remolded swell test were conducted on the sandy soils encountered in borings B-4 through B-6. The maximum dry density and optimum moisture were 128.1 pcf and 7.6 percent, respectively. The remolded swell was conducted on a sample compacted to approximately 95 percent of the maximum dry density at approximately 3 percent below optimum moisture, confined under a load of 144 psf and submerged. The resulting swell/expansion was 7.1 percent.

pH tests were conducted on various samples. The results of those tests are discussed in the **Corrosion** section below.

Results of all laboratory tests are presented in Appendix B.

## **OPINIONS AND RECOMMENDATIONS**

### **Geotechnical Considerations:**

The site is considered suitable for the proposed gabion wall repair on the geotechnical conditions encountered and tested for this report. However, potentially expansive soils were encountered on the site and tested in the laboratory. To reduce the potential for settlement or swelling, and to provide more uniform and higher allowable bearing, the gabion baskets should bear directly on cobbles or compacted gravel fill or two feet below the scour depth, whichever is greater.

The recommendations contained herein are based upon the conditions encountered in our borings, but variation in subsurface conditions may become evident during excavation and construction activities. GEOMAT should be contacted to review the recommendations contained herein should differing subsurface conditions be encountered.

If there are any significant deviations from the assumed floor elevations, structure locations and/or loads noted at the beginning of this report, the opinions and recommendations of this report should be reviewed and confirmed/modified as necessary to reflect the final planned design conditions.

### **Foundations:**

#### *Gabion Retaining Wall:*

Based on our understanding of the type of structure to be built and the results of our field subsurface exploration and laboratory testing, the gabion retaining wall could be founded on the native gravel and cobbles or 2 feet below the scour depth, whichever is deeper. To provide a more uniform bearing surface, a six-inch gravel base could be placed on top of the gravels and cobbles and extend a minimum of 6 inches beyond the edges of the gabion wall on each side or as required by the final gabion wall design. Prior to placement of the gravel base the existing subgrade, once properly cleared and benched where necessary, should be proof rolled under observation by GEOMAT. Walls supported in this manner may be designed for an allowable bearing pressure of 2,000 psf.

The existing sandy and gravelly soils can be used as backfill behind the gabion retaining wall in non-structural or landscape areas provided that any material greater than 6-inches in diameter is removed and the material is uniformly graded. If used, a unit weight of 110 pcf, cohesion of 0 psf, and internal friction angle of 30 degrees may be used in design for the existing gravelly soils. Native soils should be compacted in accordance with the **Placement and Compaction** portion of the report. In structural, parking areas, or as required, imported backfill soils should be used and meet the criteria given in the **Fill Materials** portion of this report and compacted in accordance with the **Placement and Compaction** portion of the report. Any existing lean clay material encountered should not be used as backfill.

Ground water was encountered in our borings and should be anticipated during construction. Dewatering will likely be necessary to facilitate installation of the proposed gabion walls and necessary earthwork operations including compaction of soils. Total and differential settlements resulting from the assumed structural loads are estimated to be on the order of three fourths (3/4) of an inch or less. Proper drainage should be provided in the final design and during construction and areas adjacent to the structure should be designed to prevent water from ponding or accumulating next to the structures.



Foundation excavations should be observed by GEOMAT. If the soil conditions encountered differ significantly from those presented in this report, supplemental recommendations will be required.

**Corrosion:**

Representative samples of soil from borings B-1 through B-6 were tested to evaluate the potential for the on-site soils to corrode buried metal. The samples were tested for pH. Results of these tests are summarized in the following table.

pH Test Results			
Sample No.	Boring No.	Sample Depth (feet)	pH
15280	B-1	5	7.73
15284	B-2	7 ½	7.86
15286	B-3	3 – 5	8.05
15288	Combined <sup>1</sup>	0 – 5	7.96

<sup>1</sup>Sample is a combination of auger cuttings from Borings B-4 through B-6

**Site Classification:**

Based on the subsurface conditions encountered in the borings, we estimate that Site Class D is appropriate in accordance with the International Building Code. This parameter was estimated based on extrapolation of data beyond the deepest depth explored, using methods allowed by the code. Actual shear wave velocity testing/analysis and/or exploration to a depth of 100 feet were not performed as part of our scope of services for this project.

**Lateral Earth Pressures:**

For soils above any free water surface, recommended equivalent fluid pressures for unrestrained foundation elements are presented in the following table:

**Active (above the water table – excluding any hydrostatic pressures):**

Granular soil backfill .....	35 psf/ft
Undisturbed subsoil .....	30 psf/ft

**Active (below the water table – excluding the hydrostatic pressures):**

Granular soil backfill .....	20 psf/ft
Undisturbed subsoil .....	15 psf/ft

**Passive (above the water table – excluding any hydrostatic pressures):**

Shallow foundation walls .....	250 psf/ft
Shallow column footings.....	350 psf/ft

**Passive (below the water table – excluding any hydrostatic pressures):**

Shallow foundation walls .....	150 psf/ft
Shallow column footings.....	175 psf/ft

**Coefficient of base friction:** .....0.40

The coefficient of base friction should be reduced to 0.30 when used in conjunction with passive pressure.

Fill against retaining walls should be compacted to densities specified in **Earthwork**. Medium to high plasticity clay soils should not be used as backfill against retaining walls. Compaction of each lift adjacent to walls should be accomplished with hand-operated tampers or other lightweight compactors. Over compaction may cause excessive lateral earth pressures that could result in wall movement. Dewatering will likely be required in areas to facilitate compaction efforts.

**Slopes:**

Assuming fill specifications, compaction requirements, and recommended setbacks provided in this report are followed, temporary cut and fill slopes of fill areas as steep as to 2.5:1 (horizontal:vertical) should be stable. Surcharge loads should be set back a minimum distance equal to the height of the wall unless the wall is designed for those surcharges. Depending upon specific project conditions, adequate factors of safety against slope failure may be available for steeper configurations. However, such a determination would require additional analysis. Recommendations for slopes and benches during site clearing for fill earthwork are given in the Site Clearing portion of this report.

**Earthwork:**

General Considerations:

The opinions contained in this report for the proposed construction are contingent upon compliance with recommendations presented in this section. Although underground facilities such as foundations, septic tanks, cesspools, basements, and irrigation systems were not encountered during site reconnaissance, such features could exist and might be encountered during construction.

Site Clearing:

1. Strip and remove all existing pavement, fill, debris, and other deleterious materials from the proposed building areas. Any existing structures should be completely removed from below any building, including foundation elements and any associated development such as underground utilities, septic tanks, etc. All exposed surfaces below footings and slabs should be free of mounds and depressions which could prevent uniform compaction.
2. If unexpected fills or underground facilities are encountered during site clearing, we should be contacted for further recommendations. All excavations should be observed by GEOMAT prior to backfill placement.
3. Stripped materials consisting of vegetation and organic materials should be removed from the site or used to re-vegetate exposed slopes after completion of grading operations. If it is necessary to dispose of organic materials on-site, they should be placed in non-structural areas, and in fill sections not exceeding 5 feet in height.
4. Sloping areas steeper than 5:1 (horizontal:vertical) should be benched to reduce the potential for slippage between existing slopes and fills. Benches should be level and wide enough to accommodate compaction and earth-moving equipment and at heights not exceeding 4 feet.
5. All exposed areas which will receive fill, once properly cleared and benched where necessary, should be scarified to a minimum depth of eight inches, conditioned to near optimum moisture content and compacted to at least 95% of modified proctor (ASTM D1557). If gravels and cobbles are present at the bottom of the over excavation, they should be proof compacted under observation by GEOMAT.

Excavation:

1. We present the following general comments regarding our opinion of the excavation conditions for the designers' information with the understanding that they are opinions based on our boring data. More accurate information regarding the excavation conditions should be evaluated by contractors or other interested parties from test excavations using the equipment that will be used during construction. Based on our subsurface evaluation it appears that excavations in soils at the site will be possible using standard excavation equipment.
2. On-site soils may pump or become unstable or unworkable at high water contents, especially for excavations near the water table. Dewatering may be necessary to achieve a stable excavation. Workability may be improved by scarifying and drying. Over-excavation of wet zones and replacement with granular materials may be necessary. Lightweight excavation equipment may be required to reduce subgrade pumping.

Fill Materials:

1. Based upon the conditions encountered and tested, the clayey native soils will not be suitable for reuse as structural (engineered) fill. The native sandy and gravel soils can be used as backfill behind the wall. It is the responsibility of the contractor to determine the appropriate methods for providing suitable structural (engineered) fill material prior to bidding the work. Periodic quality control testing during construction will be required to determine the suitability of native soils to be re-used as engineered fill.
2. Imported soils to be used in structural (engineered) fills should conform to the following:

<u>Gradation</u>	<u>Percent Finer by Weight (ASTM C136)</u>
3" .....	100
No. 4 Sieve .....	50 – 100
No. 200 Sieve .....	20-50
<u>Plasticity Index</u> .....	12 Max
<u>Maximum Expansive Potential (%)</u> * .....	+ 1.5

\* Measured on a sample compacted to approximately 95 percent of the ASTM D1557 maximum dry density at about 3 percent below optimum water content. The sample is confined under a 144-psf surcharge and submerged.

4. Aggregate base should conform to Type I or II Base Course as specified in Section 303 of the 2019 New Mexico Department of Transportation (NMDOT “Standard Specifications for Highway and Bridge Construction”.

Placement and Compaction:

1. Place and compact fill in horizontal lifts, using equipment and procedures that will produce recommended moisture contents and densities throughout the lift.
2. Un-compacted fill lifts should not exceed 10 inches loose thickness.

3. Materials should be compacted to the following:

<b><u>Material</u></b>	<b><u>Minimum Percent</u></b> <b><u>(ASTM D1557)</u></b>
Subgrade soils beneath fill areas .....	95
On site or imported soil fills	
On site or imported soils .....	95
Miscellaneous backfill.....	95

4. On-site and imported soils should be compacted at moisture contents near optimum.

Compliance:

Recommendations for slabs-on-grade and foundation elements supported on compacted fills depend upon compliance with **Earthwork** recommendations. To assess compliance, observation and testing should be performed by GEOMAT.

**Drainage:**

Surface Drainage:

1. Positive drainage should be provided during construction and maintained throughout the life of the proposed project. Infiltration of water into utility or foundation excavations must be prevented during construction. Planters and other surface features that could retain water in areas adjacent to the building or pavements should be sealed or eliminated.
2. In areas where sidewalks or paving do not immediately adjoin the structure, we recommend that protective slopes be provided with a minimum grade of approximately 5 percent for at least 10 feet from perimeter walls. Backfill against footings, exterior walls, and in utility and sprinkler line trenches should be well compacted and free of all construction debris to reduce the possibility of moisture infiltration.
3. Downspouts, roof drains or scuppers should discharge into splash blocks or extensions when the ground surface beneath such features is not protected by exterior slabs or paving.
4. Sprinkler systems should not be within 5 feet of foundation walls. Irrigated landscaping adjacent to the foundation system should be minimized or eliminated.

## **GENERAL COMMENTS**

It is recommended that GEOMAT be retained to provide a general review of final design plans and specifications in order to confirm that grading and foundation recommendations in this report have been interpreted and implemented. In the event that any changes of the proposed project are planned, the opinions and recommendations contained in this report should be reviewed and the report modified or supplemented as necessary.

GEOMAT should also be retained to provide services during excavation, grading, foundation, and construction phases of the work. Observation of footing excavations should be performed prior to placement of reinforcing and concrete to confirm that satisfactory bearing materials are present and is considered a necessary part of continuing geotechnical engineering services for the project. Construction testing, including field and laboratory evaluation of fill, backfill, pavement materials, concrete and steel should be performed to determine whether applicable project requirements have been met.

The analyses and recommendations in this report are based in part upon data obtained from the field exploration. The nature and extent of variations beyond the location of test borings may not become evident until construction. If variations then appear evident, it may be necessary to re-evaluate the recommendations of this report.

Our professional services were performed using that degree of care and skill ordinarily exercised, under similar circumstances, by reputable geotechnical engineers practicing in this or similar localities at the same time. No warranty, express or implied, is intended or made. We prepared the report as an aid in the design of the proposed project. This report is not a bidding document. Any contractor reviewing this report must draw his own conclusions regarding site conditions and specific construction equipment and techniques to be used on this project.

This report is for the exclusive purpose of providing geotechnical engineering and/or testing information and recommendations. The scope of services for this project does not include, either specifically or by implication, any environmental assessment of the site or identification of contaminated or hazardous materials or conditions. If the owner is concerned about the potential for such contamination, other studies should be undertaken. This report has also not addressed any geologic hazards that may exist on or near the site.

This report may be used only by the Client and only for the purposes stated, within a reasonable time from its issuance. Land use, site conditions (both on and off site), or other factors may change over time and additional work may be required with the passage of time. Any party, other than the Client, who wishes to use this report, shall notify GEOMAT in writing of such intended use. Based on the intended use of the report, GEOMAT may require that additional work be performed and that an updated report be issued. Non-compliance with any of these requirements, by the Client or anyone else, will release GEOMAT from any liability resulting from the use of this report by an unauthorized party.

# **Appendix A**



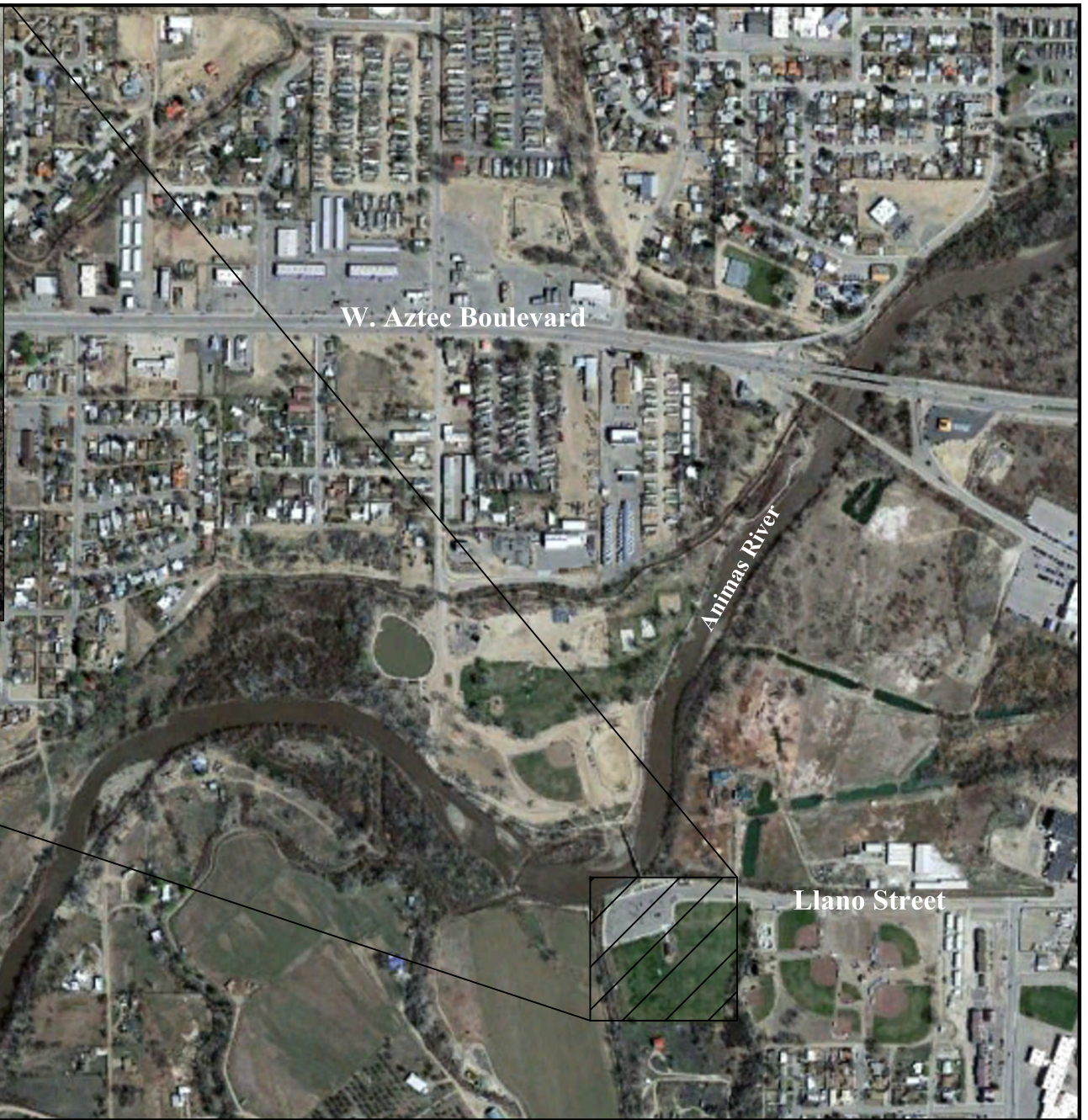

Approximate  
Not to Scale

VICINITY PLAN
Boring Locations (approximate)
GEOMAT Project No. 232-4570
Date of Exploration: August 28, 2023

PROJECT
Williams Arroyo Gabion Wall Repair Aztec, New Mexico



915 Malta Ave  
Farmington, NM 87401  
Tel (505) 327-7928  
Fax (505) 326-5721

# Boring B-1

Page 1 of 1

Project Name: <u>Williams Arroyo Gabion Wall Repair</u>	Date Drilled: <u>8/28/2023</u>
Project Number: <u>232-4570</u>	Latitude: <u>Not Determined</u>
Client: <u>Aqua Strategies</u>	Longitude: <u>Not Determined</u>
Site Location: <u>Aztec, New Mexico</u>	Elevation: <u>Not Determined</u>
Rig Type: <u>CME-55</u>	Boring Location: <u>See Site Plan</u>
Drilling Method: <u>7.25" O.D. Hollow Stem Auger</u>	Groundwater Depth: <u>5 1/2</u>
Sampling Method: <u>Ring and Split spoon samples</u>	Logged By: <u>CB</u>
Hammer Weight: <u>140 lbs</u>	Remarks: <u>None</u>
Hammer Fall: <u>30 inches</u>	

Laboratory Results				Blows per 6"	Sample Type & Length (in)	Symbol	Material Type	Soil Symbol	Depth (ft)	Soil Description
Dry Density (pcf)	% Passing #200 Sieve	Plasticity Index	Moisture Content (%)							
97.1	-	-	14.1	3-4	R	☒	SM		1	Grass and topsoil approx. thickness 6"
									2	Silty SAND, light brown to brown, fine- to coarse-grained, very loose, damp
									3	
									4	
				2-1-1	SS	☒			5	sandy lens
									6	wet
									6	Lean CLAY, light gray/brown, soft, wet
81.7	-	-	33.8	2-3	R	☒	CL		7	
									8	
									9	gravel lens
									10	Poorly Graded SAND, brown/gray, fine- to medium-grained, rounded particles, wet
				2-2-12	SS	☒	SP		11	Well Graded GRAVEL with silt, tan to brown/white, fine- to coarse-grained, wet
									12	
									13	
									14	
				4-5-10	SS	☒	GW-GM		15	gravel and cobble lens
									16	
									17	Total Depth 16 1/2 feet
									18	
									19	
									20	

GEO MAT 232-4570.GPJ GEO MAT.GDT 10/4/23

A = Auger Cuttings R = Ring-Lined Barrel Sampler SS = Split Spoon GRAB = Manual Grab Sample D = Disturbed Bulk Sample SH = Shelby Tube Sampler



915 Malta Ave  
Farmington, NM 87401  
Tel (505) 327-7928  
Fax (505) 326-5721

# Boring B-2

Page 1 of 1

Project Name: <u>Williams Arroyo Gabion Wall Repair</u>	Date Drilled: <u>8/28/2023</u>
Project Number: <u>232-4570</u>	Latitude: <u>Not Determined</u>
Client: <u>Aqua Strategies</u>	Longitude: <u>Not Determined</u>
Site Location: <u>Aztec, New Mexico</u>	Elevation: <u>Not Determined</u>
Rig Type: <u>CME-55</u>	Boring Location: <u>See Site Plan</u>
Drilling Method: <u>7.25" O.D. Hollow Stem Auger</u>	Groundwater Depth: <u>6</u>
Sampling Method: <u>Ring and Split spoon samples</u>	Logged By: <u>CB</u>
Hammer Weight: <u>140 lbs</u>	Remarks: <u>None</u>
Hammer Fall: <u>30 inches</u>	

Laboratory Results				Blows per 6"	Sample Type & Length (in)	Symbol	Material Type	Soil Symbol	Depth (ft)	Soil Description
Dry Density (pcf)	% Passing #200 Sieve	Plasticity Index	Moisture Content (%)							
-	30	NP	17.5	2-3-2	SS		SM		1	Grass and topsoil approx. thickness 6"
-	51	NP	31.4	1-1-2	SS		ML		2	Silty SAND, brown/gray, fine- to medium-grained, very loose, slightly damp to damp
									3	
									4	
									5	Sandy SILT, brown to gray, soft, damp to wet
									6	
									7	
				2-8-16	SS		SM		8	Silty SAND with gravel, tan to brown/white, fine- to coarse-grained, dense, wet
									9	
									10	
				39-20-21	SS		SM		11	
									12	
				15-12-35	SS		GP		13	Gravels and cobbles
									14	
									15	auger refusal on gravel and cobbles Total Depth 14 feet

GEO MAT 232-4570.GPJ GEO MAT.GDT 10/4/23

A = Auger Cuttings R = Ring-Lined Barrel Sampler SS = Split Spoon GRAB = Manual Grab Sample D = Disturbed Bulk Sample SH = Shelby Tube Sampler



915 Malta Ave  
Farmington, NM 87401  
Tel (505) 327-7928  
Fax (505) 326-5721

# Boring B-3

Page 1 of 1

Project Name: <u>Williams Arroyo Gabion Wall Repair</u>	Date Drilled: <u>8/28/2023</u>
Project Number: <u>232-4570</u>	Latitude: <u>Not Determined</u>
Client: <u>Aqua Strategies</u>	Longitude: <u>Not Determined</u>
Site Location: <u>Aztec, New Mexico</u>	Elevation: <u>Not Determined</u>
Rig Type: <u>CME-55</u>	Boring Location: <u>See Site Plan</u>
Drilling Method: <u>7.25" O.D. Hollow Stem Auger</u>	Groundwater Depth: <u>5 1/2</u>
Sampling Method: <u>Ring and Split spoon samples</u>	Logged By: <u>CB</u>
Hammer Weight: <u>140 lbs</u>	Remarks: <u>None</u>
Hammer Fall: <u>30 inches</u>	

Laboratory Results				Blows per 6"	Sample Type & Length (in)	Symbol	Material Type	Soil Symbol	Depth (ft)	Soil Description				
Dry Density (pcf)	% Passing #200 Sieve	Plasticity Index	Moisture Content (%)											
104.8	-	-	11.8	2-3	R	A	SM		1	Silty SAND, light brown to tan, fine- to coarse-grained, dry to slightly damp				
							SC		2	Clayey SAND, brown/gray, fine- to coarse-grained, very loose to medium dense, slightly damp to damp				
				1-4-11	SS	X	CL		3	4	gravel lens	5	6	Sandy Lean CLAY with gravel, tan to brown/gray, stiff, moist to wet
									7	8	Silty SAND with gravel, brown, fine- to coarse-grained, wet			
				13-15-50/5"	SS	X	SM		9	GW-GM		Well Graded GRAVEL with silt, brown/gray, fine- to coarse-grained, wet		
							GP		10	Gravels and cobbles				
				13-13-11	SS	X	GP		11	12	auger refusal on gravel and cobbles Total Depth 11 1/2 feet			
									13	14	15			

GEO MAT 232-4570.GPJ GEO MAT.GDT 10/4/23

A = Auger Cuttings R = Ring-Lined Barrel Sampler SS = Split Spoon GRAB = Manual Grab Sample D = Disturbed Bulk Sample SH = Shelby Tube Sampler



915 Malta Ave  
Farmington, NM 87401  
Tel (505) 327-7928  
Fax (505) 326-5721

# Boring B-4

Page 1 of 1

Project Name: <u>Williams Arroyo Gabion Wall Repair</u>	Date Drilled: <u>8/28/2023</u>
Project Number: <u>232-4570</u>	Latitude: <u>Not Determined</u>
Client: <u>Aqua Strategies</u>	Longitude: <u>Not Determined</u>
Site Location: <u>Aztec, New Mexico</u>	Elevation: <u>Not Determined</u>
Rig Type: <u>CME-55</u>	Boring Location: <u>See Site Plan</u>
Drilling Method: <u>7.25" O.D. Hollow Stem Auger</u>	Groundwater Depth: <u>7</u>
Sampling Method: <u>Ring and Split spoon samples</u>	Logged By: <u>CB</u>
Hammer Weight: <u>140 lbs</u>	Remarks: <u>None</u>
Hammer Fall: <u>30 inches</u>	

Laboratory Results					Blows per 6"	Sample Type & Length (in)	Symbol	Material Type	Soil Symbol	Depth (ft)	Soil Description
Dry Density (pcf)	% Passing #200 Sieve	Plasticity Index	Moisture Content (%)								
				1-1-1	SS		SM		1	Silty SAND, light brown to brown/tan, fine- to coarse-grained, very loose to medium dense, dry to slightly damp	
									2		
									3	gravel and cobbles lens no recovery	
					GRAB				4		
				8-20	R				5	no recovery	
									6		
							GW-GM		7	Well Graded GRAVEL with silt, brown/gray, fine- to coarse-grained, damp to wet	
				50/4"	SS				8		
									9	Gravels and cobbles no recovery	
				50/1/2"	SS		GP		10		
									11	auger refusal on gravel and cobbles Total Depth 10 feet	
									12		
									13		
									14		
									15		

GEO MAT 232-4570.GPJ GEO MAT.GDT 10/4/23

A = Auger Cuttings R = Ring-Lined Barrel Sampler SS = Split Spoon GRAB = Manual Grab Sample D = Disturbed Bulk Sample SH = Shelby Tube Sampler



915 Malta Ave  
Farmington, NM 87401  
Tel (505) 327-7928  
Fax (505) 326-5721

# Boring B-5

Page 1 of 1

Project Name: <u>Williams Arroyo Gabion Wall Repair</u>	Date Drilled: <u>8/28/2023</u>
Project Number: <u>232-4570</u>	Latitude: <u>Not Determined</u>
Client: <u>Aqua Strategies</u>	Longitude: <u>Not Determined</u>
Site Location: <u>Aztec, New Mexico</u>	Elevation: <u>Not Determined</u>
Rig Type: <u>CME-55</u>	Boring Location: <u>See Site Plan</u>
Drilling Method: <u>7.25" O.D. Hollow Stem Auger</u>	Groundwater Depth: <u>Not Encountered</u>
Sampling Method: <u>Ring and Split spoon samples</u>	Logged By: <u>CB</u>
Hammer Weight: <u>140 lbs</u>	Remarks: <u>None</u>
Hammer Fall: <u>30 inches</u>	

Laboratory Results				Blows per 6"	Sample Type & Length (in)	Symbol	Material Type	Soil Symbol	Depth (ft)	Soil Description
Dry Density (pcf)	% Passing #200 Sieve	Plasticity Index	Moisture Content (%)							
				43-41-34	SS		GC		1	Clayey GRAVEL with cobbles and sand, brown/tan/gray, fine- to coarse-grained, dry to slightly damp
									2	
									3	
					GRAB				4	
				50/6"	SS				5	
									6	auger refusal on gravel and cobbles Total Depth 5 1/2 feet
									7	
									8	
									9	
									10	

GEO MAT 232-4570.GPJ GEO MAT.GDT 10/4/23

A = Auger Cuttings R = Ring-Lined Barrel Sampler SS = Split Spoon GRAB = Manual Grab Sample D = Disturbed Bulk Sample SH = Shelby Tube Sampler



915 Malta Ave  
Farmington, NM 87401  
Tel (505) 327-7928  
Fax (505) 326-5721

# Boring B-6

Page 1 of 1

Project Name: <u>Williams Arroyo Gabion Wall Repair</u>	Date Drilled: <u>8/28/2023</u>
Project Number: <u>232-4570</u>	Latitude: <u>Not Determined</u>
Client: <u>Aqua Strategies</u>	Longitude: <u>Not Determined</u>
Site Location: <u>Aztec, New Mexico</u>	Elevation: <u>Not Determined</u>
Rig Type: <u>CME-55</u>	Boring Location: <u>See Site Plan</u>
Drilling Method: <u>7.25" O.D. Hollow Stem Auger</u>	Groundwater Depth: <u>Not Encountered</u>
Sampling Method: <u>Ring and Split spoon samples</u>	Logged By: <u>CB</u>
Hammer Weight: <u>140 lbs</u>	Remarks: <u>None</u>
Hammer Fall: <u>30 inches</u>	

Laboratory Results				Blows per 6"	Sample Type & Length (in)	Symbol	Material Type	Soil Symbol	Depth (ft)	Soil Description
Dry Density (pcf)	% Passing #200 Sieve	Plasticity Index	Moisture Content (%)							
-	24	15	10.0	5-8-9	SS		GC		1	Clayey GRAVEL with cobbles and sand, brown/tan/gray, fine-to coarse-grained, dry to slightly damp
									2	
									3	
									4	
				12-10-8	SS				5	
									6	
									7	no recovery
				50/2"	SS				8	auger refusal on gravel and cobbles
									9	Total Depth 7 feet
									10	

GEO MAT 232-4570.GPJ GEO MAT.GDT 10/4/23

A = Auger Cuttings R = Ring-Lined Barrel Sampler SS = Split Spoon GRAB = Manual Grab Sample D = Disturbed Bulk Sample SH = Shelby Tube Sampler

UNIFIED SOIL CLASSIFICATION SYSTEM						CONSISTENCY OR RELATIVE DENSITY CRITERIA				
Major Divisions				Group Symbols	Typical Names					
<b>Coarse-Grained Soils</b>  More than 50% retained on No. 200 sieve	<b>Gravels</b> 50% or more of coarse fraction retained on No. 4 sieve	Clean Gravels	GW	Well-graded gravels and gravel-sand mixtures, little or no fines		Penetration Resistance, N (blows/ft.)	Standard Penetration Test Density of Granular Soils			
			GP	Poorly graded gravels and gravel-sand mixtures, little or no fines			Relative Density			
		Gravels with Fines	GM	Silty gravels, gravel-sand-silt mixtures			0-4	Very Loose		
			GC	Clayey gravels, gravel-sand-clay mixtures			5-10	Loose		
	<b>Sands</b> More than 50% of coarse fraction passes No. 4 sieve	Clean Sands	SW	Well-graded sands and gravelly sands, little or no fines		11-30	Medium Dense			
			SP	Poorly graded sands and gravelly sands, little or no fines		31-50	Dense			
		Sands with Fines	SM	Silty sands, sand-silt mixtures		>50	Very Dense			
			SC	Clayey sands, sand-clay mixtures		Standard Penetration Test Density of Fine-Grained Soils				
<b>Fine-Grained Soils</b>  50% or more passes No. 200 sieve	<b>Silts and Clays</b> Liquid Limit 50 or less	ML	Inorganic silts, very fine sands, rock flour, silty or clayey fine sands		Penetration Resistance, N (blows/ft.)	Consistency	Unconfined Compressive Strength (Tons/ft <sup>2</sup> )			
		CL	Inorganic clays of low to medium plasticity, gravelly clays, sandy clays, silty clays, lean clays					<2	Very Soft	<0.25
		OL	Organic silts and organic silty clays of low plasticity					2-4	Soft	0.25-0.50
	<b>Silts and Clays</b> Liquid Limit greater than 50	MH	Inorganic silts, micaceous or diatomaceous free sands or silts, elastic silts					4-8	Firm	0.50-1.00
		CH	Inorganic clays of high plasticity, fat clays					8-15	Stiff	1.00-2.00
		OH	Organic clays of medium to high plasticity					15-30	Very Stiff	2.00-4.00
		Highly Organic Soils		PT				Peat, mucic & other highly organic soils		>30
U.S. Standard Sieve Sizes										
>12"	12"	3"	3/4"	#4	#10	#40	#200			
Boulders	Cobbles	Gravel		Sand			Silt or Clay			
		coarse	fine	coarse	medium	fine				

**MOISTURE CONDITIONS**

Dry	Absence of moist, dusty, dry to the touch
Slightly Damp	Below optimum moisture content for compaction
Moist	Near optimum moisture content, will moisten the hand
Very Moist	Above optimum moisture content
Wet	Visible free water, below water table

**MATERIAL QUANTITY**

trace	0-5%
few	5-10%
little	10-25%
some	25-45%
mostly	50-100%

**OTHER SYMBOLS**

R	Ring Sample
S	SPT Sample
B	Bulk Sample
▼	Ground Water

**BASIC LOG FORMAT:**

Group name, Group symbol, (grain size), color, moisture, consistency or relative density. Additional comments: odor, presence of roots, mica, gypsum, coarse particles, etc.

**EXAMPLE:**

SILTY SAND w/trace silt (SM-SP), Brown, loose to med. Dense, fine to medium grained, damp

**UNIFIED SOIL CLASSIFICATION SYSTEM**



## **TEST DRILLING EQUIPMENT & PROCEDURES**

### **Description of Subsurface Exploration Methods**

**Drilling Equipment** – Truck-mounted drill rigs powered with gasoline or diesel engines are used in advancing test borings. Drilling through soil or softer rock is performed with hollow-stem auger or continuous flight auger. Carbide insert teeth are normally used on bits to penetrate soft rock or very strongly cemented soils which require blasting or very heavy equipment for excavation. Where refusal is experienced in auger drilling, the holes are sometimes advanced with tricone gear bits and NX rods using water or air as a drilling fluid.

**Coring Equipment** – Portable electric core drills are used when recovery of asphalt or concrete cores is necessary. The core drill is equipped with either a 4” or 6” diameter diamond core barrel. Water is generally used as a drilling fluid to facilitate cooling and removal of cuttings from the annulus.

**Sampling Procedures** - Dynamically driven tube samples are usually obtained at selected intervals in the borings by the ASTM D1586 test procedure. In most cases, 2” outside diameter, 1 3/8” inside diameter, samplers are used to obtain the standard penetration resistance. “Undisturbed” samples of firmer soils are often obtained with 3” outside diameter samplers lined with 2.42” inside diameter brass rings. The driving energy is generally recorded as the number of blows of a 140-pound, 30-inch free fall drop hammer required to advance the samplers in 6-inch increments. These values are expressed in blows per foot on the boring logs. However, in stratified soils, driving resistance is sometimes recorded in 2- or 3-inch increments so that soil changes and the presence of scattered gravel or cemented layers can be readily detected and the realistic penetration values obtained for consideration in design. “Undisturbed” sampling of softer soils is sometimes performed with thin-walled Shelby tubes (ASTM D1587). Tube samples are labeled and placed in watertight containers to maintain field moisture contents for testing. When necessary for testing, larger bulk samples are taken from auger cuttings. Where samples of rock are required, they are obtained by NX diamond core drilling (ASTM D2113).

**Boring Records** - Drilling operations are directed by our field engineer or geologist who examines soil recovery and prepares boring logs. Soils are visually classified in accordance with the Unified Soil Classification System (ASTM D2487), with appropriate group symbols being shown on the logs.



**Gabion Wall near at Boring B-2  
View Towards the South**



**Drill Rig at Boring B-1  
View Towards the North**



**Damaged Gabion Wall near Boring B-3  
View Towards the South**



**Piping behind Damaged Gabion Wall near Boring B-3  
View Towards the East**



**Damaged Gabion Wall near Boring B-3  
View Towards the North**



**Fill Behind Gabion Wall near Boring B-3  
View Towards the East**



**Gabion Wall near Boring B-4  
View Towards the Northeast**



**Riverview of Gabion Wall near Boring B-4  
View Towards the East**



**Riverview of Gabion Wall near Boring B-4  
View Towards the East**



**Riverview of Gabion Wall near Boring B-5  
View Towards the East**

# Appendix B

LAB NO.	BORING NO.	SAMPLE DEPTH (ft)	SIEVE ANALYSIS, CUMULATIVE PERCENT PASSING (%)												ATTERBERG LIMITS			ASTM D1557		SWELL (%)	MOISTURE CONTENT (%)	DENSITY		CLASSIFICATION
			¾"	½"	⅜"	No. 4	No. 8	No. 10	No. 16	No. 30	No. 40	No. 50	No. 100	No. 200	LIQUID LIMIT	PLASTIC LIMIT	PLASTICITY INDEX	DENSITY	MOISTURE			WET (pcf)	DRY (pcf)	
15279	B-1	2.5	-	-	-	-	-	-	-	-	-	-	-	-	-	-	-	-	-	-	14.1	110.8	97.1	Clayey SAND (SC)
15280*	B-1	5	-	-	-	-	-	-	-	-	-	-	-	-	-	-	-	-	-	-	-	-	-	Clayey SAND (SC)
15281	B-1	7.5	-	-	-	-	-	-	-	-	-	-	-	-	-	-	-	-	-	-	33.8	109.3	81.7	Lean CLAY (CL)
15282	B-2	2.5	-	-	-	-	-	-	-	-	-	-	-	30	NLL	NPL	NP	-	-	-	17.5	-	-	Silty SAND (SM)
15283	B-2	5	-	-	-	-	-	-	-	-	-	-	-	51	NLL	NPL	NP	-	-	-	31.4	-	-	Sandy SILT (ML)
15284*	B-2	7.5	-	-	-	-	-	-	-	-	-	-	-	-	-	-	-	-	-	-	-	-	-	Silty SAND (SM)
15285	B-3	2.5	-	-	-	-	-	-	-	-	-	-	-	-	-	-	-	-	-	-	11.8	117.2	104.8	Clayey SAND (SC)
15286*	B-3	3 to 5	-	-	-	-	-	-	-	-	-	-	-	-	-	-	-	-	-	-	-	-	-	Clayey SAND (SC)
15287	B-6	2.5	-	-	-	-	-	-	-	-	-	-	-	24	32	17	15	-	-	-	10.0	-	-	Clayey SAND (SC)
15288*	Combined B-4 thru B-6	0 to 5	100	98	95	91	89	88	86	76	68	60	48	38	35	19	16	128.1	7.6	6.2	-	-	-	Clayey SAND (SC)

NLL = No Liquid Limit  
NPL = No Plastic Limit  
NP = Non-Plastic  
\* = pH Testing

	<b>SUMMARY OF SOIL TESTS</b> Page 1 of 1	Project Name	Williams Arroyo Gabion Wall Repair
		Project No.	232-4570
		Location	Aztec, New Mexico
		Date(s) of Exploration	8/28/2023



## LABORATORY TESTING PROCEDURES

Laboratory testing is performed by trained personnel in our accredited laboratory or may be subcontracted by GEOMAT through a qualified outside laboratory if necessary. Actual types and quantities of tests performed for any project will be dependent upon subsurface conditions encountered and specific design requirements.

The following is an abbreviated table of laboratory testing that may be performed by GEOMAT with the applicable standards listed. Testing for a specific project may include all or a selected subset of the laboratory work listed. Laboratory testing beyond those listed may be available and could be incorporated into the project scope at the discretion of GEOMAT.

PROCEDURE	ASTM	AASHTO
Moisture Content	ASTM D2216	AASHTO T 265
Sieve Analysis	ASTM C136	AASHTO T 27
Fines Content	ASTM D1140	T 11
Hydrometer	ASTM D422	T 88
Atterberg Limits	ASTM D4318	AASHTO T 89/T 90
Soil Compression/Expansion	ASTM D2435	T 216
Soil Classification	ASTM D2487	M 145
Direct Shear	ASTM D3080	T 236
Unconfined Compressive Strength of Soils	ASTM D2166	T 208
Unconfined Compressive Strength of Rock Cores	ASTM D4543	-

# Appendix C

# Important Information about This

# Geotechnical-Engineering Report

Subsurface problems are a principal cause of construction delays, cost overruns, claims, and disputes.

While you cannot eliminate all such risks, you can manage them. The following information is provided to help.

**The Geoprofessional Business Association (GBA) has prepared this advisory to help you – assumedly a client representative – interpret and apply this geotechnical-engineering report as effectively as possible. In that way, you can benefit from a lowered exposure to problems associated with subsurface conditions at project sites and development of them that, for decades, have been a principal cause of construction delays, cost overruns, claims, and disputes. If you have questions or want more information about any of the issues discussed herein, contact your GBA-member geotechnical engineer. Active engagement in GBA exposes geotechnical engineers to a wide array of risk-confrontation techniques that can be of genuine benefit for everyone involved with a construction project.**

## Understand the Geotechnical-Engineering Services Provided for this Report

Geotechnical-engineering services typically include the planning, collection, interpretation, and analysis of exploratory data from widely spaced borings and/or test pits. Field data are combined with results from laboratory tests of soil and rock samples obtained from field exploration (if applicable), observations made during site reconnaissance, and historical information to form one or more models of the expected subsurface conditions beneath the site. Local geology and alterations of the site surface and subsurface by previous and proposed construction are also important considerations. Geotechnical engineers apply their engineering training, experience, and judgment to adapt the requirements of the prospective project to the subsurface model(s). Estimates are made of the subsurface conditions that will likely be exposed during construction as well as the expected performance of foundations and other structures being planned and/or affected by construction activities.

The culmination of these geotechnical-engineering services is typically a geotechnical-engineering report providing the data obtained, a discussion of the subsurface model(s), the engineering and geologic engineering assessments and analyses made, and the recommendations developed to satisfy the given requirements of the project. These reports may be titled investigations, explorations, studies, assessments, or evaluations. Regardless of the title used, the geotechnical-engineering report is an engineering interpretation of the subsurface conditions within the context of the project and does not represent a close examination, systematic inquiry, or thorough investigation of all site and subsurface conditions.

## Geotechnical-Engineering Services are Performed for Specific Purposes, Persons, and Projects, and At Specific Times

Geotechnical engineers structure their services to meet the specific needs, goals, and risk management preferences of their clients. A geotechnical-engineering study conducted for a given civil engineer

will not likely meet the needs of a civil-works constructor or even a different civil engineer. Because each geotechnical-engineering study is unique, each geotechnical-engineering report is unique, prepared *solely* for the client.

Likewise, geotechnical-engineering services are performed for a specific project and purpose. For example, it is unlikely that a geotechnical-engineering study for a refrigerated warehouse will be the same as one prepared for a parking garage; and a few borings drilled during a preliminary study to evaluate site feasibility will not be adequate to develop geotechnical design recommendations for the project.

Do not rely on this report if your geotechnical engineer prepared it:

- for a different client;
- for a different project or purpose;
- for a different site (that may or may not include all or a portion of the original site); or
- before important events occurred at the site or adjacent to it; e.g., man-made events like construction or environmental remediation, or natural events like floods, droughts, earthquakes, or groundwater fluctuations.

Note, too, the reliability of a geotechnical-engineering report can be affected by the passage of time, because of factors like changed subsurface conditions; new or modified codes, standards, or regulations; or new techniques or tools. *If you are the least bit uncertain* about the continued reliability of this report, contact your geotechnical engineer before applying the recommendations in it. A minor amount of additional testing or analysis after the passage of time – if any is required at all – could prevent major problems.

## Read this Report in Full

Costly problems have occurred because those relying on a geotechnical-engineering report did not read the report in its entirety. Do not rely on an executive summary. Do not read selective elements only. *Read and refer to the report in full.*

## You Need to Inform Your Geotechnical Engineer About Change

Your geotechnical engineer considered unique, project-specific factors when developing the scope of study behind this report and developing the confirmation-dependent recommendations the report conveys. Typical changes that could erode the reliability of this report include those that affect:

- the site's size or shape;
- the elevation, configuration, location, orientation, function or weight of the proposed structure and the desired performance criteria;
- the composition of the design team; or
- project ownership.

As a general rule, *always* inform your geotechnical engineer of project or site changes – even minor ones – and request an assessment of their impact. *The geotechnical engineer who prepared this report cannot accept*

responsibility or liability for problems that arise because the geotechnical engineer was not informed about developments the engineer otherwise would have considered.

### Most of the “Findings” Related in This Report Are Professional Opinions

Before construction begins, geotechnical engineers explore a site’s subsurface using various sampling and testing procedures. *Geotechnical engineers can observe actual subsurface conditions only at those specific locations where sampling and testing is performed.* The data derived from that sampling and testing were reviewed by your geotechnical engineer, who then applied professional judgement to form opinions about subsurface conditions throughout the site. Actual sitewide-subsurface conditions may differ – maybe significantly – from those indicated in this report. Confront that risk by retaining your geotechnical engineer to serve on the design team through project completion to obtain informed guidance quickly, whenever needed.

### This Report’s Recommendations Are Confirmation-Dependent

The recommendations included in this report – including any options or alternatives – are confirmation-dependent. In other words, they are not final, because the geotechnical engineer who developed them relied heavily on judgement and opinion to do so. Your geotechnical engineer can finalize the recommendations *only after observing actual subsurface conditions* exposed during construction. If through observation your geotechnical engineer confirms that the conditions assumed to exist actually do exist, the recommendations can be relied upon, assuming no other changes have occurred. *The geotechnical engineer who prepared this report cannot assume responsibility or liability for confirmation-dependent recommendations if you fail to retain that engineer to perform construction observation.*

### This Report Could Be Misinterpreted

Other design professionals’ misinterpretation of geotechnical-engineering reports has resulted in costly problems. Confront that risk by having your geotechnical engineer serve as a continuing member of the design team, to:

- confer with other design-team members;
- help develop specifications;
- review pertinent elements of other design professionals’ plans and specifications; and
- be available whenever geotechnical-engineering guidance is needed.

You should also confront the risk of constructors misinterpreting this report. Do so by retaining your geotechnical engineer to participate in prebid and preconstruction conferences and to perform construction-phase observations.

### Give Constructors a Complete Report and Guidance

Some owners and design professionals mistakenly believe they can shift unanticipated-subsurface-conditions liability to constructors by limiting the information they provide for bid preparation. To help prevent the costly, contentious problems this practice has caused, include the complete geotechnical-engineering report, along with any attachments or appendices, with your contract documents, *but be certain to note*

*conspicuously that you’ve included the material for information purposes only.* To avoid misunderstanding, you may also want to note that “informational purposes” means constructors have no right to rely on the interpretations, opinions, conclusions, or recommendations in the report. Be certain that constructors know they may learn about specific project requirements, including options selected from the report, *only* from the design drawings and specifications. Remind constructors that they may perform their own studies if they want to, and *be sure to allow enough time* to permit them to do so. Only then might you be in a position to give constructors the information available to you, while requiring them to at least share some of the financial responsibilities stemming from unanticipated conditions. Conducting prebid and preconstruction conferences can also be valuable in this respect.

### Read Responsibility Provisions Closely

Some client representatives, design professionals, and constructors do not realize that geotechnical engineering is far less exact than other engineering disciplines. This happens in part because soil and rock on project sites are typically heterogeneous and not manufactured materials with well-defined engineering properties like steel and concrete. That lack of understanding has nurtured unrealistic expectations that have resulted in disappointments, delays, cost overruns, claims, and disputes. To confront that risk, geotechnical engineers commonly include explanatory provisions in their reports. Sometimes labeled “limitations,” many of these provisions indicate where geotechnical engineers’ responsibilities begin and end, to help others recognize their own responsibilities and risks. *Read these provisions closely.* Ask questions. Your geotechnical engineer should respond fully and frankly.

### Geoenvironmental Concerns Are Not Covered

The personnel, equipment, and techniques used to perform an environmental study – e.g., a “phase-one” or “phase-two” environmental site assessment – differ significantly from those used to perform a geotechnical-engineering study. For that reason, a geotechnical-engineering report does not usually provide environmental findings, conclusions, or recommendations; e.g., about the likelihood of encountering underground storage tanks or regulated contaminants. *Unanticipated subsurface environmental problems have led to project failures.* If you have not obtained your own environmental information about the project site, ask your geotechnical consultant for a recommendation on how to find environmental risk-management guidance.

### Obtain Professional Assistance to Deal with Moisture Infiltration and Mold

While your geotechnical engineer may have addressed groundwater, water infiltration, or similar issues in this report, the engineer’s services were not designed, conducted, or intended to prevent migration of moisture – including water vapor – from the soil through building slabs and walls and into the building interior, where it can cause mold growth and material-performance deficiencies. Accordingly, *proper implementation of the geotechnical engineer’s recommendations will not of itself be sufficient to prevent moisture infiltration.* **Confront the risk of moisture infiltration** by including building-envelope or mold specialists on the design team. **Geotechnical engineers are not building-envelope or mold specialists.**



Telephone: 301/565-2733  
e-mail: [info@geoprofessional.org](mailto:info@geoprofessional.org) [www.geoprofessional.org](http://www.geoprofessional.org)