

NOTES

1. AS DETERMINED BY A.S.T.M. D-1557 A.A.S.H.O. DEG T-147 MOISTURE CONTENT OF ALL COMPACTED SUBGRADE MATERIAL IN PLACE SHALL BE NO GREATER THAN OPTIMUM NOR ANY LESS THAN OPTIMUM MINUS 5%
2. ALL PAVEMENT CUT EDGES WILL BE TRIMMED TO PRESENT AN EVEN LINE PRIOR TO REPLACEMENT OF PAVING MATERIALS
3. OR MATCH EXISTING THICKNESS - WHICH EVER IS GREATER (WITH ENGINEER APPROVAL)

REV.	DATE
△	12/31/97
△	1/20/99
△	12/9/02

CONSTRUCTION  
STANDARDS

PAVEMENT PATCHING  
CITY STREET

STANDARD No. D-306-1 SHEET 1 OF 2

CITY OF  
AZTEC  
PUBLIC WORKS  
DEPARTMENT

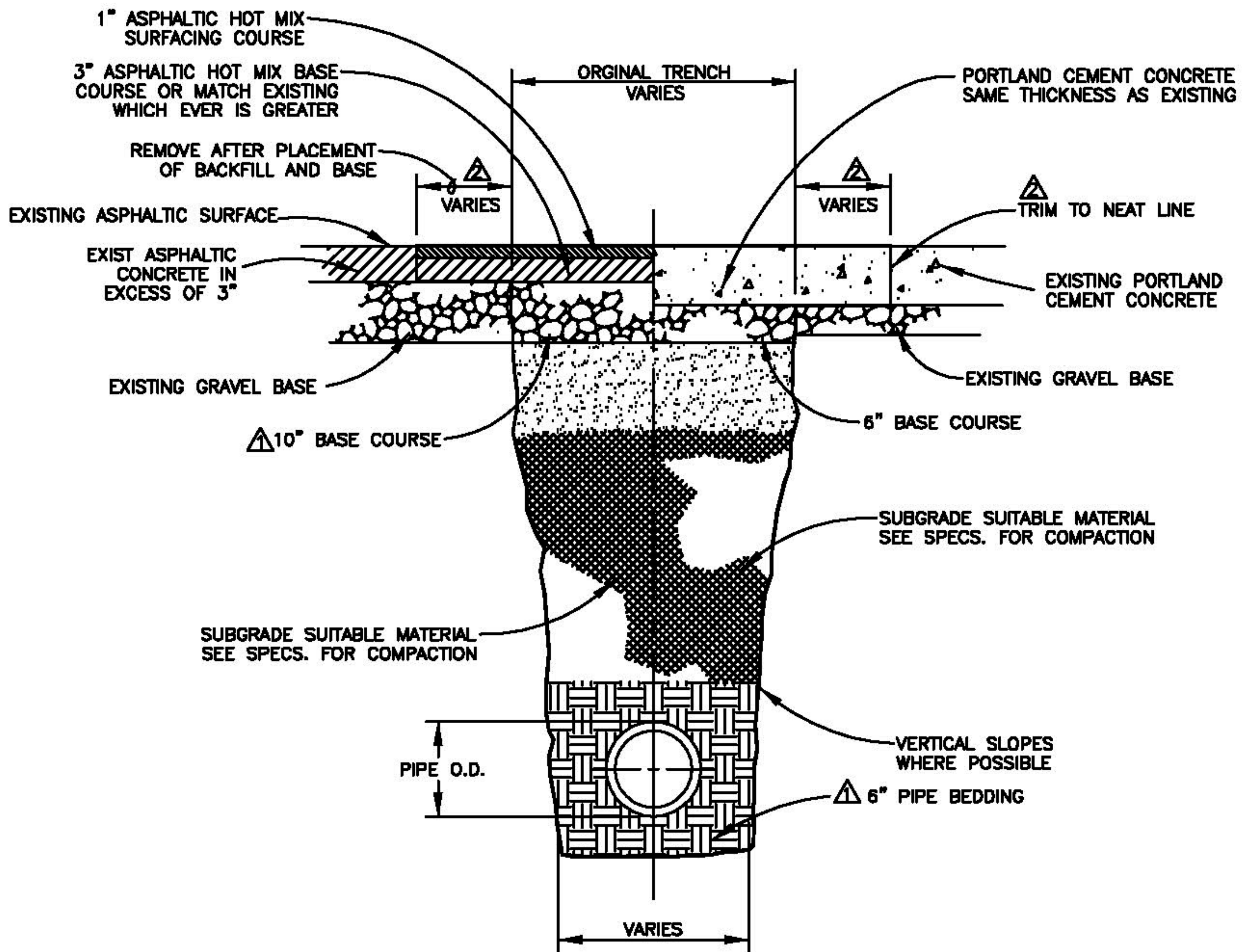

NOTES

1. AS DETERMINED BY A.S.T.M. D-1557 A.A.S.H.O. DEG T-147 MOISTURE CONTENT OF ALL COMPACTED SUBGRADE MATERIAL IN PLACE SHALL BE NO GREATER THAN OPTIMUM MINUS 5%
2. ALL PAVEMENT CUT EDGES WILL BE TRIMMED TO PRESENT AN EVEN LINE PRIOR TO REPLACEMENT OF PAVING MATERIALS

REV.	DATE
△	12/31/97
△	1/20/99
△	12/9/02

CONSTRUCTION  
STANDARDS

PAVEMENT PATCHING  
CITY STREET

STANDARD No. D-306-2 SHEET 2 OF 2

CITY OF  
AZTEC  
PUBLIC WORKS  
DEPARTMENT